



Rockwood and Green's

Fractures in Adults

EIGHTH EDITION

tahir99 - UnitedVRG



Vol. 1

EDITORS

Charles M. Court-Brown
James D. Heckman
Margaret M. McQueen
William M. Ricci
Paul Tornetta III

ASSOCIATE EDITOR

Michael D. McKee

ROCKWOOD AND GREEN'S
Fractures in Adults

EIGHTH EDITION

Volume 1

ROCKWOOD AND GREEN'S Fractures in Adults

EIGHTH EDITION

EDITORS

Charles M. Court-Brown, MD, FRCS Ed (Orth)
Professor of Orthopaedic Trauma
Royal Infirmary of Edinburgh
Edinburgh, United Kingdom

James D. Heckman, MD
Editor-in-Chief
The Journal of Bone & Joint Surgery
Needham, Massachusetts
Clinical Professor of Orthopaedic Surgery
Harvard Medical School
Visiting Orthopaedic Surgeon
Department of Orthopaedic Surgery
Massachusetts General Hospital
Boston, Massachusetts

Margaret M. McQueen, MD, FRCS Ed (Orth)
Professor of Orthopaedic Trauma
The University of Edinburgh
Edinburgh, United Kingdom

William M. Ricci, MD
Professor and Chief
Orthopaedic Trauma Service
Department of Orthopaedic Surgery
Washington University School of Medicine
St. Louis, Missouri

Paul Tornetta III, MD
Professor and Vice Chairman
Department of Orthopaedic Surgery
Boston University School of Medicine
Director of Orthopaedic Trauma
Boston Medical Center
Boston, Massachusetts

ASSOCIATE EDITOR

Michael D. McKee, MD, FRCS(C)
Professor
Upper Extremity Reconstructive Service
Department of Surgery
Division of Orthopaedics
St. Michael's Hospital and the University of
Toronto
Toronto, Canada

 Wolters Kluwer

Philadelphia • Baltimore • New York • London
Buenos Aires • Hong Kong • Sydney • Tokyo

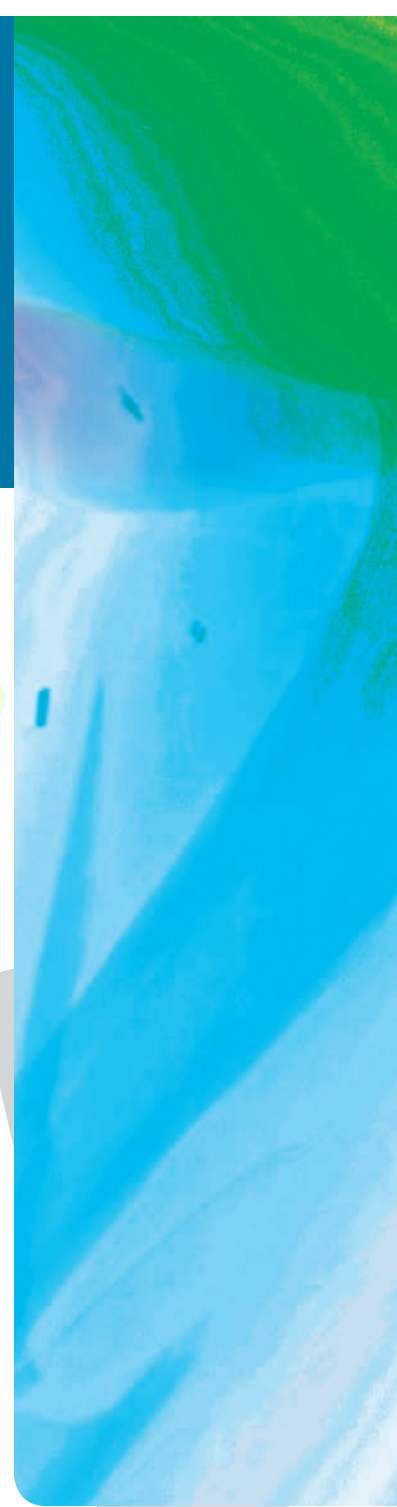

Acquisitions Editor: Brian Brown
Product Development Editor: David Murphy
Production Project Manager: David Orzechowski
Design Coordinator: Joan Wendt
Manufacturing Coordinator: Beth Welch
Prepress Vendor: Aptara, Inc.

8th edition

Copyright © 2015 Wolters Kluwer Health

Copyright © 2010 Wolters Kluwer Health / Lippincott Williams & Wilkins. Copyright © 2008 Lippincott Williams & Wilkins, a Wolters Kluwer business. Copyright © 2004, 2000 by Lippincott Williams & Wilkins. Copyright © 1996 by Lippincott-Raven Publishers. Copyright © 1992, 1988, 1984, 1980, 1975, 1970, 1964 by J. B. Lippincott Company.

Two Commerce Square
2001 Market Street
Philadelphia, PA 19103 USA
LWW.com

All rights reserved. This book is protected by copyright. No part of this book may be reproduced or transmitted in any form or by any means, including as photocopies or scanned-in or other electronic copies, or utilized by any information storage and retrieval system without written permission from the copyright owner, except for brief quotations embodied in critical articles and reviews. Materials appearing in this book prepared by individuals as part of their official duties as U.S. government employees are not covered by the above-mentioned copyright. To request permission, please contact Wolters Kluwer Health at Two Commerce Square, 2001 Market Street, Philadelphia, PA 19103, via email at permissions@lww.com, or via our website at lww.com (products and services).

9 8 7 6 5 4 3 2 1

Printed in China

Library of Congress Cataloging-in-Publication Data

Rockwood and Green's fractures in adults / [edited by] Charles M. Court-Brown, James D. Heckman, Margaret M. McQueen, William Ricci, Paul Tornetta III; associate editor, Michael McKee. – Eighth edition.

p. ; cm.

Fractures in adults

Includes bibliographical references and index.

ISBN 978-1-4511-7531-8 (hardback : alk. paper)

I. Court-Brown, Charles M., editor. II. Heckman, James D., editor. III. McQueen, Margaret M., editor. IV. Ricci, William M., editor. V. Tornetta, Paul, III, editor. VI. McKee, Michael D., editor. VII. Title: Fractures in adults.

[DNLM: 1. Fractures, Bone. 2. Adult. 3. Dislocations. WE 175]

RD101

617.1'5—dc23

2014016563

Care has been taken to confirm the accuracy of the information presented and to describe generally accepted practices. However, the author(s), editors, and publisher are not responsible for errors or omissions or for any consequences from application of the information in this book and make no warranty, expressed or implied, with respect to the currency, completeness, or accuracy of the contents of the publication. Application of this information in a particular situation remains the professional responsibility of the practitioner; the clinical treatments described and recommended may not be considered absolute and universal recommendations.

The author(s), editors, and publisher have exerted every effort to ensure that drug selection and dosage set forth in this text are in accordance with the current recommendations and practice at the time of publication. However, in view of ongoing research, changes in government regulations, and the constant flow of information relating to drug therapy and drug reactions, the reader is urged to check the package insert for each drug for any change in indications and dosage and for added warnings and precautions. This is particularly important when the recommended agent is a new or infrequently employed drug.

Some drugs and medical devices presented in this publication have Food and Drug Administration (FDA) clearance for limited use in restricted research settings. It is the responsibility of the health care provider to ascertain the FDA status of each drug or device planned for use in his or her clinical practice.

We dedicate this Eighth Edition of Rockwood and Green's: Fractures in Adults to Charles A. Rockwood, Jr, MD, and David P. Green, MD, who served as our inspiration and mentors for carrying on the revision and update of this textbook.

To Susan for her patience and understanding during my 30-year tenure on the editorial board.

JDH

To the future: Emily, Jessica, and Rosie.

CCB

To my children Sacha, Tyler, Robbin, and Everett for enriching my life every day, and my partner Niloofar for her love and support.

MMcK

To Caroline, Elizabeth, and William without whom life would be easier but much less fun.

MMcQ

To Ann, Michael, and Luke, my reasons for being, for their patience, love, and support.

WMR

To my mother Phyllis, who found the best in people, had compassion for all, and whose insight, guidance, and love have always made me believe that anything is possible.

PT3

Contributors



Adewale O. Adeniran, MD Resident, Department of Surgery, Dartmouth-Hitchcock Medical Center, Lebanon, New Hampshire

Animesh Agarwal, MD Professor and Chief, Department of Orthopaedics, Division of Orthopaedic Trauma, University of Texas Health Science Center, Director of Orthopaedic Trauma, University Hospital, San Antonio, Texas

Devendra Agraharam, DNB Associate Consultant in Trauma, Ganga Hospital, Coimbatore, India

Romney C. Andersen, MD Clinical Assistant Professor of Orthopaedics, University of Maryland Medical Center, Baltimore, Maryland

George S. Athwal, MD, FRCSC Associate Professor of Surgery, Western University, Consultant, Roth-McFarlane Hand and Upper Limb Centre, St Joseph's Health Care, Ontario, Canada

Roger M. Atkins, MA, MB, BS, DM, FRCS Consultant Orthopaedic Surgeon, Bristol Royal Infirmary, Bristol, England

David P. Barei, MD, FRCSC Associate Professor, Department of Orthopaedics, Harborview Medical Center, University of Washington, Seattle, Washington

Jan Bartoniček MD, DSc Professor and Chairman, Department of Orthopaedic Trauma, 1st Faculty of Medicine of Charles University Prague and Central Military Hospital Prague, Department of Anatomy, 1st Faculty of Medicine of Charles University Prague, Prague, Czech Republic

Daphne M. Beingessner, BMath, BSc, MSc, MD, FRCSC Associate Professor, Department of Orthopaedics and Sports Medicine, University of Washington, Orthopaedic Traumatology, Harborview Medical Center, Seattle, Washington

Mohit Bhandari, MD, PhD, FRCSC Professor and Head, Division of Orthopedic Surgery, Associate Chair, Research, Department of Surgery, Canada Research Chair in Musculoskeletal Trauma, Associate Faculty, Department of Clinical Epidemiology and Biostatistics, McMaster University, Ontario, Canada

Leela C. Biant, BSc(hons), MBBS, AFRCSed, FRCS (Tr & Orth), MS(res)Lond Consultant Trauma & Orthopaedic Surgeon, The Royal Infirmary of Edinburgh, Honorary Senior Lecturer, The University of Edinburgh, NRS Career Clinician Scientist Fellow, Edinburgh, United Kingdom

Aaron J. Bois, MD, MSc, FRCSC Section of Orthopaedic Surgery, Department of Surgery, University of Calgary, Alberta, Canada

Brett Bolhofner, MD Director, Orthopaedic Trauma Services, Bayfront Medical Center, Clinical Assistant Professor, University of South Florida College of Medicine, Saint Petersburg, Florida

Christopher M. Bono, MD Associate Professor, Department of Orthopaedic Surgery, Brigham and Women's Hospital, Harvard Medical School, Boston, Massachusetts

Christina Boulton, MD Assistant Professor of Orthopaedics, Department of Orthopaedics, R Adams Cowley Shock Trauma Center, Department of Orthopaedics, University of Maryland School of Medicine, Baltimore, Maryland

Mark R. Brinker, MD Director of Acute and Reconstructive Trauma, Co-Director, The Center for Problem Fractures and Limb Restoration, Texas Orthopedic Hospital, Fendren Orthopedic Group, Houston, Texas, Clinical Professor, Department of Orthopaedic Surgery, Tulane University School of Medicine, New Orleans, Louisiana, Clinical Professor, Joseph Barnhart Department of Orthopedic Surgery, Baylor College of Medicine, Clinical Professor Department of Orthopedic Surgery, The University of Texas Medical School at Houston, Houston, Texas

Kate E. Bugler, BA, MRCS Specialty Registrar, Clinical Research Fellow, Orthopaedic Trauma Unit, Royal Infirmary of Edinburgh, Edinburgh, United Kingdom

Harvey Chim, MBBS Hand Surgery Fellow, Department of Orthopedic Surgery, Division of Hand Surgery, Mayo Clinic, Rochester, Minnesota

David Ciceri, MD Assistant Professor of Anesthesiology, Director, Surgical Intensive Care, Scott & White HealthCare, Texas A&M Health Science Center, Temple, Texas

Michael P. Clare, MD Director of Fellowship Education, Foot & Ankle Fellowship, Florida Orthopaedic Institute, Tampa, Florida

Nicholas D. Clement, MRCSEd Orthopaedic Research Fellow, Department of Trauma and Orthopaedic Surgery, Royal Infirmary of Edinburgh, Edinburgh, United Kingdom

Cory A. Collinge, MD Director of Orthopaedic Trauma, Harris Methodist Fort Worth Hospital, Clinical Staff, John Peter Smith Hospital, Fort Worth, Texas

Marlon O. Coulibaly, MD Assistant Professor, Department of General and Trauma Surgery, Rhur-University Bochum, Attending Orthopaedic Surgeon, Department of General and Trauma Surgery, Berufsgenossenschaftliches Universitätsklinikum Bergmannshiel GmbH, Bochum, Germany

Charles M. Court-Brown, MD, FRCS Ed (Orth) Professor of Orthopaedic Trauma, Royal Infirmary of Edinburgh, Edinburgh, United Kingdom

Anthony DeGiacomo, MD Orthopaedic Surgery Resident, Boston University, Boston, Massachusetts

J. Dheenadhayalan, MS Senior Consultant in Trauma and Upper Limb Service, Ganga Hospital, Coimbatore, India

Douglas R. Dirschl, MD Professor and Chairman, Department of Orthopaedic Surgery, University of Chicago Medicine and Biological Sciences, Chicago, Illinois

Paul J. Dougherty, MD Residency Program Director, Detroit Medical Center, Detroit, Michigan, Associate Professor, Residency Director, Department of Orthopaedic Surgery, University of Michigan, Ann Arbor, Michigan

Andrew D. Duckworth, MSc, MRCSEd Edinburgh Orthopaedic Trauma Unit, Royal Infirmary of Edinburgh, Edinburgh, United Kingdom

Anil K. Dutta, MD Associate Professor, Fred G. Corley, MD Distinguished Professorship in Orthopaedics, Shoulder

and Elbow Surgery, Department of Orthopaedics, University of Texas Health Science Center, San Antonio, Texas

Cory Edgar, MD, PhD, Assistant Professor and Team Physician, University of Connecticut, Farmington, Connecticut

Thomas A. Einhorn, MD Chairman, Department of Orthopaedic Surgery, Professor of Orthopaedic Surgery, Biochemistry and Biomedical Engineering, Department of Orthopaedic Surgery, Boston University Medical Center, Boston, Massachusetts

William J. J. Ertl, MD Associate Professor, Department of Orthopaedics and Rehabilitation, The University of Oklahoma, Oklahoma City, Oklahoma

Michael J. Gardner, MD Associate Professor, Department of Orthopedic Surgery, Washington University School of Medicine, St. Louis, Missouri

Christos Garnavos, MD, PhD Consultant Orthopaedic Surgeon, Department of Orthopaedics, Evangelismos General Hospital, Athens, Greece

Peter V. Giannoudis, MD, FRCS Professor of Trauma & Orthopaedic Surgery, School of Medicine, University of Leeds, Leeds General Infirmary University Hospital, Leeds, United Kingdom

George J. Haidukewych, MD Director of Orthopedic Trauma, Chief of Complex Joint Replacement, Academic Chairman for the Orthopedic Faculty Practice, Professor, University of Central Florida College of Medicine, Orlando, Florida

Mark H. Henry, MD Hand & Wrist Center of Houston, Houston, Texas

Martin F. Hoffman, MD Assistant Professor, Department of General and Trauma Surgery, Rhur-University Bochum, Attending Orthopaedic Surgeon, Department of General and Trauma Surgery, Berufsgenossenschaftliches Universitätsklinikum Bergmannshiel GmbH, Bochum, Germany

Andrew Jawa, MD Assistant Professor of Orthopedic Surgery, Boston University School of Medicine, Boston, Massachusetts

Mark Jo, MD Huntington Orthopedics, Pasadena, California

Leo Joskowicz, PhD Professor, School of Engineering and Computer Science, The Hebrew University of Jerusalem, Jerusalem, Israel

Christopher C. Kaeding, MD The Ohio State University Sports Medicine Center, Judson Wilson Professor, Department of Orthopaedics, Co-Medical Director, Sports Medicine Center, Head Team Physician, Department of Athletics, The Ohio State University, Columbus, Ohio

Michael S. Kain, MD Director, Resident Education, Department of Orthopaedics, Lahey Hospital & Medical Center, Burlington, Massachusetts

Sanjeev Kakar, MD, MRCS Assistant Professor, Department of Orthopaedic Surgery, Mayo Clinic, Rochester, Minnesota

Kerry M. Kallas, MD Musculoskeletal Radiologist, Center for Diagnostic Imaging, Sartell, Minnesota

Matthew D. Karam, MD Assistant Professor of Orthopaedic Surgery, The University of Iowa, Iowa City, Iowa

Madhav A. Karunakar, MD Associate Professor, Orthopaedic Traumatologist, Department of Orthopaedic Surgery, Carolinas Medical Center, Charlotte, North Carolina

John F. Keating, MPhil, FRCS(Ed) (Orth) Consultant Orthopaedic Surgeon, Royal Infirmary of Edinburgh, Edinburgh, United Kingdom

Christopher K. Kepler, MD Department of Orthopaedic Surgery, Thomas Jefferson University, Philadelphia, Pennsylvania

Hubert T. Kim, MD, PhD Associate Professor and Vice Chairman, Department of Orthopaedic Surgery, University of California, Director, Department of Orthopaedic Surgery, UCSF Cartilage Repair and Regeneration Center, UCSF Orthopaedic Institute, San Francisco, California

Graham J.W. King, MD, MSc, FRCSC Professor, Departments of Surgery and Biomedical Engineering, Western University, Director, Roth McFarlane Hand and Upper Limb Centre, St. Joseph's Health Centre, London, Ontario, Canada

Erik N. Kubiak, MD Associate Professor, Department of Orthopaedics, University of Utah Medical Center, Salt Lake City, Utah

Joshua Langford, MD Orthopedic Traumatologist, Level One Orthopedics at Orlando Health, Orlando, Florida

Meir Liebergall, MD Professor of Orthopaedic Surgery, Hebrew University, Chairman, Department of Orthopaedic Surgery, The Hadassah-Hebrew University Medical Center, Jerusalem, Israel

Mark J. Lemos, MD Associate Professor of Orthopaedic Surgery, Boston University School of Medicine, Vice Chair, Department of Orthopaedic Surgery, Director of Sports Medicine, Lahey Hospital & Medical Center, Burlington, Massachusetts

Bruce A. Levy, MD Professor, Department of Orthopedics and Sports Medicine, Mayo Clinic, Rochester, Minnesota

Ralph Marcucio, PhD Associate Professor, Department of Orthopaedic Surgery, University of California, Director, Laboratory for Skeletal Regeneration, Orthopaedic Surgery, UCSF/SFGH Orthopaedic Trauma Institute, San Francisco General Hospital, San Francisco, California

J. L. Marsh, MD The Carroll B. Larson Professor of Orthopaedic Surgery, The University of Iowa, Iowa City, Iowa

Augustus D. Mazzocca, MS, MD Professor, Department of Orthopaedic Surgery, UConn Health Center, Director, Department of Orthopaedic Surgery, Division of Clinical Biomechanics, Director, Bioskills Laboratory, Farmington, Connecticut

Michael D. McKee, MD, FRCS(C) Professor, Upper Extremity Reconstructive Service, Department of Surgery, Division of Orthopaedics, St. Michael's Hospital and the University of Toronto, Toronto, Canada

Margaret M. McQueen, MD, FRCS Ed (Orth) Professor of Orthopaedic Trauma, The University of Edinburgh, Edinburgh, United Kingdom

J. Stuart Melvin, MD OrthoCarolina, Charlotte, North Carolina

Theodore Miclau III, MD Professor and Vice Chair, Department of Orthopaedic Surgery, University of California, Chief of Service, Director, UCSF/SFGH Orthopaedic Trauma Institute, Department of Orthopaedic Surgery, San Francisco General Hospital, San Francisco, California

Timothy L. Miller, MD Team Physician for The Ohio State University Track and Field and Cross-Country Teams, Assistant Director of The Ohio State University Medical Center Endurance Medicine Team, The Ohio State University Sports Medicine Center, Columbus, Ohio

Sohail K. Mirza, MD Professor of Orthopaedic Surgery, Professor of the Dartmouth Institute, Dartmouth-Hitchcock Medical Center, Lebanon, New Hampshire

Berton Moed, MD Professor and Chairman, Department of Orthopaedic Surgery, Saint Louis University School of Medicine, St. Louis, Missouri

Thomas Moore Jr, MD Assistant Professor, Department of Orthopaedics, Emory University School of Medicine, Grady Health Systems, Orthopaedic Clinic, Atlanta, Georgia

Steven L. Moran, MD Professor of Orthopedics, Professor of Plastic Surgery, Departments of Orthopaedic and Plastic Surgery, Mayo Clinic, Rochester, Minnesota

Rami Mosheiff Professor of Orthopedic Surgery, Faculty of Medicine, The Hadassah-Hebrew University, Head of Orthopedic Trauma Unit, Department of Orthopedic Surgery, The Hadassah-Hebrew University Medical Center, Jerusalem, Israel

Soheil Najibi, MD, PhD Senior Staff Orthopaedic Surgeon, Henry Ford Hospital, Detroit, Michigan

Sean E. Nork, MD Associate Professor, Department of Orthopaedic Surgery, Harborview Medical Center, Seattle, Washington

Carol North, MD The Nancy and Ray L. Hunt Chair in Crisis Psychiatry, Professor, Departments of Psychiatry and Surgery/Division, Emergency Medicine/Section on Homeland Security, The University of Texas Southwestern Medical Center, Dallas, Texas

Daniel P. O'Connor, PhD Associate Professor, Laboratory of Integrated Physiology, University of Houston, Houston, Texas

Robert V. O'Toole, MD Associate Professor of Orthopaedics, R Adams Cowley Shock Trauma Center, Department of Orthopaedics, University of Maryland School of Medicine, Baltimore, Maryland

Hans Christoph Pape, MD Professor of Trauma & Orthopaedic Surgery, Department of Orthopaedic Trauma Surgery, University Clinic Aachen, RWTH University Aachen, Aachen, Germany

Adam M. Pearson, MD Assistant Professor, Department of Orthopaedic Surgery, Dartmouth-Hitchcock Medical Center, Lebanon, New Hampshire

R. Perumal, DNB Associate Consultant in Trauma Ganga Hospital, Coimbatore, India

Rodrigo F. Pesántez, MD Chief of Orthopaedic Trauma, Departamento de Ortopedia y Traumatología, Fundación Santa Fe de Bogotá, Universidad de los Andes, Bogotá, Colombia

J. Whitcomb Pollock, MD, MSc, FRCSC Assistant Professor, Department of Surgery, University of Ottawa, Ontario, Canada, The Ottawa Hospital General Campus, Ontario, Canada

Robert Probe, MD Professor of Surgery, Chairman, Department of Orthopaedic Surgery, Scott & White Health-Care, Texas A&M Health Science Center, Temple, Texas

Robert H. Quinn, M.D. Professor and Chairman, Residency Program Director, John J. Hinchey M.D. and Kathryn Hinchey Chair in Orthopaedic Surgery, Orthopaedic Oncology, Department of Orthopaedics, University of Texas School of Medicine, San Antonio, Texas

Rajiv Rajani, MD Assistant Professor, Department of Orthopaedics, University of Texas School of Medicine, San Antonio, Texas

S. Rajasekaran, MS, FRCS, MCh, DNB, PhD Chairman, Department of Orthopaedic & Spine Surgery, Ganga Hospital, Coimbatore, India

Stuart H. Ralston, MB ChB, MD, FRCP, FRSE Arthritis Research UK Professor of Rheumatology, Institute of Genetics and Molecular Medicine, Western General Hospital, University of Edinburgh, Edinburgh, United Kingdom

Nalini Rao, MD, FACP, FSHEA Clinical Professor of Medicine and Orthopedics, University of Pittsburgh School of Medicine, Chief, Division of Infectious Diseases (Shadyside Campus), UPMC Presbyterian Shadyside, Medical Director, Infection Control, UPMC Shadyside, Southside and Braddock, Pittsburgh, Pennsylvania

Mark C. Reilly, MD Associate Professor and Chief Orthopaedic Trauma Service, Department of Orthopaedic Surgery, New Jersey Medical School, Newark, New Jersey

Eric T. Ricchetti, MD Staff, Department of Orthopaedic Surgery, Orthopedic and Rheumatologic Institute, Cleveland Clinic, Cleveland, Ohio

William M. Ricci, MD Professor, Chief, Orthopaedic Trauma Service, Department of Orthopaedic Surgery, Washington University School of Medicine, St. Louis, Missouri

David Ring, MD, PhD Chief, Hand and Upper Extremity Service, Director of Research, Hand and Upper Extremity Service, Massachusetts General Hospital, Associate Professor of Orthopaedic Surgery, Harvard Medical School, Boston, Massachusetts

Charles A. Rockwood, Jr, MD Professor and Chairman Emeritus of Orthopaedics, Director, Shoulder Service, University of Texas Health Science Center, San Antonio, Texas

Thomas P. Rüedi, MD, FACS Professor Dr med, FACS, Founding Member of the AO Foundation, Davos, Switzerland

Thomas A. Russell, MD Professor of Orthopaedic Surgery, Department of Orthopaedic Surgery, University of Tennessee and Campbell Clinic, University of Tennessee Center for the Health Sciences, Elvis Presley Trauma Center and Regional Medical Center, Memphis, Tennessee

Joaquin Sanchez-Sotelo, MD PhD Associate Professor of Orthopaedic Surgery, Department of Orthopedic Surgery, Mayo Clinic, Rochester, Minnesota

David W. Sanders, MD, MSc, FRCS(C) Associate Professor, Victoria Hospital, Western University, Ontario, Canada

Roy W. Sanders, MD Director, Orthopaedic Trauma Service, Florida Orthopaedic Institute, Chief, Department of Orthopaedic Surgery, Tampa General Hospital, Tampa, Florida

Adam A. Sassoon, MD Department of Orthopaedic Surgery, Orlando Regional Medical Center, Orlando, Florida

Thomas A. Schildhauer Clinical Professor, Department of General and Trauma Surgery, Rhur-University Bochum, Medical Director and Chairman, Department of General and Trauma Surgery, Berufsgenossenschaftliches Universitätsklinikum Bergmannshiel GmbH, Bochum, Germany

Andrew H. Schmidt, MD Professor, Department of Orthopaedic Surgery, University of Minnesota, Director of Clinical Research, Department of Orthopedic Surgery, Hennepin County Medical Center, Minneapolis, Minnesota

Andrew J. Schoenfeld, MD Assistant Professor, Department of Orthopaedic Surgery, Texas Tech University Health Sciences Center, William Beaumont Army Medical Center, El Paso, Texas

Michael Schütz, FRACS, FAOrthA, Dr. med. (RWTH Aachen) Dr. med. habil (HU Berlin) Professor and Chairman in Trauma, Science and Engineering Faculty, Institute of Health and Biomedical Innovation, Queensland University of Technology, Director of Trauma, Department of Surgery, Princess Alexandra Hospital, Queensland, Australia

Jesse Slade Shantz, MD, MBA Orthopaedic Trauma Fellow, Department of Orthopaedic Surgery, University of California, Orthopaedic Trauma Fellow, UCSF/SFGH Orthopaedic Trauma Institute, San Francisco General Hospital, San Francisco, California

Alexander Y. Shin, MD Professor and Consultant of Orthopaedic Surgery, Department of Orthopedic Surgery, Division of Hand Surgery, Mayo Clinic, Rochester, Minnesota

Sarina K. Sinclair, PhD Orthopaedics - Research Instructor, University of Utah School of Medicine, Salt Lake City, Utah

Wade R. Smith, MD, FACS Professor of Orthopaedic Surgery, University of Colorado School of Medicine, Orthopaedic Trauma Surgeon, HCA Healthone Clinical Services, Mountain Orthopaedic Trauma Surgeons at Swedish, Englewood, Colorado

Adam Starr, MD Professor, Department of Orthopaedic Surgery, University of Texas Southwestern Medical Center, Dallas, Texas

Scott P. Steinmann, MD Professor of Orthopaedic Surgery, Department of Orthopedic Surgery, Mayo Clinic, Rochester, Minnesota

Philipp N. Streubel, MD Assistant Professor, Hand and Upper Extremity Surgery, Department of Orthopaedic Surgery and Rehabilitation, University of Nebraska Medical Center, Omaha, Nebraska

S. R. Sundararajan, MS Senior Consultant in Trauma and Arthroscopy Ganga Hospital, Coimbatore, India

Allan F. Tencer, PhD Professor Emeritus, Department of Orthopaedics and Sports Medicine, University of Washington, Seattle, Washington

Paul Tornetta III, MD Professor and Vice Chairman, Department of Orthopaedic Surgery, Boston University School of Medicine, Director of Orthopaedic Trauma, Boston Medical Center, Boston, Massachusetts

Alexander R. Vaccaro, MD, PhD Everett J. and Marion Gordon Professor of Orthopaedic Surgery, Professor of Neurosurgery, Thomas Jefferson University, Vice Chairman, Department of Orthopaedic Surgery, Co-Director, Regional Spinal Cord Injury Center of the Delaware Valley, Co-Director of Spine Surgery and the Spine Fellowship program, Thomas Jefferson University Hospital, Philadelphia, Pennsylvania

Eric Wagner, MD Research Fellow, Department of Orthopaedics, Mayo Clinic, Rochester, Minnesota

J. Tracy Watson, MD Professor Orthopaedic Surgery, Chief, Orthopaedic Traumatology Service, Department of Orthopaedic Surgery, Saint Louis University School of Medicine, St. Louis University Health Sciences Center, St. Louis, Missouri

Daniel B. Whelan, MD, MSc, FRCSC Assistant Professor, University of Toronto Sports Medicine Program, Division of Orthopaedic Surgery, St. Michael's Hospital, Ontario, Canada

Timothy O. White, MD, FRCSEd(Orth) Consultant Orthopaedic Trauma Surgeon, Edinburgh Orthopaedic Trauma Unit, Royal Infirmary of Edinburgh, Edinburgh, Scotland

Michael A. Wirth, MD Professor/Charles A. Rockwood Jr., M.D. Chair, Shoulder Service, Department of Orthopaedics, University of Texas Health Science Center, Division of Orthopaedics, Audie Murphy Veterans Hospital, San Antonio, Texas

Donald A. Wiss, MD Director of Orthopaedic Trauma, Cedars-Sinai Medical Center, Los Angeles, California

Bruce H. Ziran, MD Director of Orthopaedic Trauma, Orthopaedic Residency Program, Atlanta Medical Center, Atlanta, Georgia

tahir99 - UnitedVRG

Preface



The eighth edition of *Rockwood and Green's: Fractures in Adults* continues with the changes that were instituted in the seventh edition. In this edition there are two more chapters and 61 new authors drawn from three continents and 11 different countries. In addition, many of the new authors represent the next generation of orthopedic trauma surgeons who will be determining the direction of trauma management over the next two or three decades.

Orthopedic trauma continues to be an expanding discipline, with change occurring more quickly than is often realized. When Drs. Rockwood and Green published the first edition in 1975, there were virtually no orthopedic trauma specialists in most countries, fractures were usually treated nonoperatively, and mortality following severe trauma was considerable. In one generation the changes in orthopedic surgery, as in the rest of medicine, have been formidable. We have worked to incorporate these changes in this edition. There is expanded coverage in this edition of the inevitable complications that all orthopedic surgeons have to deal with, and we have included chapters on geriatric trauma and the psychological aspects of trauma. The other area of orthopedic trauma that is expanding quickly, particularly in the developed countries, is the treatment of osteoporotic (or fragility) fractures. These fractures are assuming a greater medical and political importance, and orthopedic implants are now being designed specifically to treat elderly patients. It is likely that this trend will continue over the next

few decades; many of the chapters in this edition reflect this change in emphasis.

The changes in the eighth edition include major changes in its chapter structure. Each of the clinical chapters now follows a specific template beginning with the physical examination, classification, and additional studies used in the diagnosis of each problem. This is followed by a description of the outcome measures used to evaluate patients for the specific injury they sustained. The indications and contraindications for each treatment method, including nonoperative and operative methods are highlighted in tables, as are the technical aspects of the surgeries. Old favorites such as pitfalls and problems are also listed in tables with solutions. Finally, the author's preferred treatment is now presented in the form of an algorithm, allowing the reader to understand the thought process of the expert writer in deciding on the treatment for the multiple subtypes of injuries described in each chapter. We believe that this will make it easy to get the most out of each chapter.

Finally, we are proud to introduce a new electronic format that should allow for easier access across platforms, a change that is overdue! Video supplementation is also available for the majority of the clinical problems.

We are indebted to the efforts of the experts who have taken the time to share their knowledge and experience with our broad readership and hope that this new edition will contribute to the care of patients.

Charles M. Court-Brown, MD, FRCS Ed (Orth)
James D. Heckman, MD
Margaret M. McQueen, MD, FRCS Ed (Orth)
William M. Ricci, MD
Paul Tornetta III, MD

Contents

Contributors vii
Preface xiii

Volume 1

SECTION ONE: GENERAL PRINCIPLES

BASICS

- 1** Biomechanics of Fractures and Fracture Fixation 1
Mark J. Jo, Allan F. Tencer, and Michael J. Gardner
- 2** Classification of Fractures 43
Douglas R. Dirschl
- 3** The Epidemiology of Fractures and Dislocations 59
Charles M. Court-Brown
- 4** Bone and Cartilage Healing 109
Jesse Slade Shantz, Ralph Marcucio, Hubert T. Kim, and Theodore Miclau III
- 5** Biologic and Biophysical Technologies for the Enhancement of Fracture Repair 127
Eric Wagner, Thomas A. Einhorn, and Sanjeev Kakar

PRINCIPLES OF TREATMENT

- 6** Principles of Nonoperative Fracture Treatment 155
Charles M. Court-Brown
- 7** Principles of Internal Fixation 195
Michael Schütz and Thomas P. Rüedi
- 8** Principles of External Fixation 227
J. Tracy Watson
- 9** Management of the Multiply Injured Patient 307
Hans Christoph Pape and Peter V. Giannoudis
- 10** Initial Management of Open Fractures 353
S. Rajasekaran, A. Devendra, R. Perumal, J. Dheenadhayalan, and S.R. Sundararajan
- 11** Gunshot and Wartime Injuries 397
Paul J. Dougherty, Romney C. Andersen, and Soheil Najibi
- 12** Principles of Mangled Extremity Management 429
Sarina K. Sinclair and Erik N. Kubiak

- 13** Post-Traumatic Stress Disorder 453
Thomas Moore, Jr., Carol North, and Adam Starr
- 14** Amputations 459
William J. J. Ertl
- 15** Bone and Soft Tissue Reconstruction 473
Harvey Chim, Steven L. Moran, and Alexander Y. Shin
- 16** Outcome Studies in Trauma 517
Mohit Bhandari
- 17** Imaging Considerations in Orthopedic Trauma 541
Andrew H. Schmidt and Kerry M. Kallas
- 18** Computer-Aided Orthopedic Surgery in Skeletal Trauma 575
Meir Liebergall, Rami Mosheiff, and Leo Joskowicz
- 19** Osteoporosis 609
Stuart H. Ralston

FRACTURE TYPES

- 20** Fractures in The Elderly Patient 621
Nicholas D. Clement and Leela C. Biant
- 21** Stress Fractures 651
Timothy L. Miller and Christopher C. Kaeding
- 22** Pathologic Fractures 667
Rajiv Rajani and Robert T. Quinn
- 23** Periprosthetic Fractures 691
William M. Ricci

COMPLICATIONS

- 24** Venous Thromboembolic Disease in Patients with Skeletal Trauma 767
Robert Probe and David Ciceri
- 25** Complex Regional Pain Syndrome 779
Roger M. Atkins
- 26** Orthopedic Infections and Osteomyelitis 793
Bruce H. Ziran, Wade R. Smith, and Nalini Rao
- 27** Principles of Nonunion Treatment 827
William M. Ricci and Brett Bolhofner

28 Principles of Malunions	869	45 Thoracolumbar Spine Fractures and Dislocations	1757
<i>Mark R. Brinker and Daniel P. O'Connor</i>		<i>Christopher K. Kepler and Alexander R. Vaccaro</i>	
29 Acute Compartment Syndrome	895		
<i>Margaret M. McQueen</i>			
SECTION TWO: UPPER EXTREMITY			
30 Hand Fractures and Dislocations	915	46 Pelvic Ring Fractures	1795
<i>Mark H. Henry</i>		<i>Animesh Agarwal</i>	
31 Carpus Fractures and Dislocations	991	47 Acetabulum Fractures	1891
<i>Andrew D. Duckworth and David Ring</i>		<i>Berton R. Moed and Mark C. Reilly</i>	
32 Fractures of the Distal Radius and Ulna	1057	48 Hip Dislocations and Fractures of the Femoral Head	1983
<i>Margaret M. McQueen</i>		<i>Michael S. Kain and Paul Tornetta III</i>	
33 Diaphyseal Fractures of the Radius and Ulna	1121	49 Femoral Neck Fractures	2031
<i>Philipp N. Streubel and Rodrigo F. Pesántez</i>		<i>John F. Keating</i>	
34 Elbow Fractures and Dislocations	1179	50 Intertrochanteric Fractures of the Hip	2075
<i>Daphne M. Beingsner, J. Whitcomb Pollock, and Graham J.W. King</i>		<i>Thomas A. Russell</i>	
35 Distal Humerus Fractures	1229	51 Subtrochanteric Femur Fractures	2131
<i>George S. Athwal</i>		<i>Adam A. Sassoon, Joshua Langford, and George J. Haidukewych</i>	
36 Humeral Shaft Fractures	1287	52 Femoral Shaft Fractures	2149
<i>Christos Garnavos</i>		<i>Sean E. Nork</i>	
37 Proximal Humeral Fractures	1341	53 Distal Femur Fractures	2229
<i>Philipp N. Streubel, Joaquin Sanchez-Sotelo, and Scott P. Steinmann</i>		<i>Cory A. Collinge and Donald A. Wiss</i>	
38 Clavicle Fractures	1427	54 Patella Fractures and Extensor Mechanism Injuries	2269
<i>Michael D. McKee</i>		<i>J. Stuart Melvin and Madhav A. Karunakar</i>	
39 Scapular Fractures	1475	55 Tibial Plateau Fractures	2303
<i>Jan Bartoniček</i>		<i>J. L. Marsh and Matthew D. Karam</i>	
40 Glenohumeral Instability	1503	56 Knee Dislocations	2369
<i>Andrew Jawa and Eric T. Ricchetti</i>		<i>Daniel B. Whelan and Bruce A. Levy</i>	
41 Acromioclavicular Joint Injuries	1573	57 Tibia and Fibula Shaft Fractures	2415
<i>Cory Edgar, Anthony DeGiacomo, Mark J. Lemos, and Augustus D. Mazzocca</i>		<i>Christina Boulton and Robert V. O'Toole</i>	
42 Injuries to the Sternoclavicular Joint	1607	58 Pilon Fractures	2473
<i>Anil K. Dutta, Aaron J. Bois, Michael A. Wirth, and Charles A. Rockwood, Jr</i>		<i>David P. Barei</i>	
Volume 2			
SECTION THREE: SPINE			
43 Principles of Spine Trauma Care	1645	59 Ankle Fractures	2541
<i>Adewale O. Adeniran, Adam M. Pearson, and Sohail K. Mirza</i>		<i>Timothy O. White and Kate E. Bugler</i>	
44 Cervical Spine Fractures and Dislocations	1677	60 Fractures and Dislocations of the Talus	2593
<i>Andrew J. Schoenfeld and Christopher M. Bono</i>		<i>David W. Sanders</i>	
		61 Calcaneus Fractures	2639
		<i>Michael P. Clare and Roy W. Sanders</i>	
		62 Fractures and Dislocations of the Midfoot and Forefoot	2689
		<i>Thomas A. Schildhauer, Marlon O. Coulibaly, and Martin F. Hoffmann</i>	
		<i>Index I-1</i>	

General Principles



BIOMECHANICS OF FRACTURES AND FRACTURE FIXATION

Mark J. Jo, Allan F. Tencer, and Michael J. Gardner

- INTRODUCTION 1
- BASIC CONCEPTS 1
- BIOMECHANICS OF INTACT AND HEALING BONE 10
- BIOMECHANICS OF BONE FRACTURE 14
- BIOMECHANICS OF FRACTURE IMPLANTS 17
 - *Avoiding Mechanical Problems with Fracture Fixation Devices* 17
 - *Biomechanical Aspects of Fracture Fixation in Specific Locations* 32
- SUMMARY 39

INTRODUCTION TO BIOMECHANICS OF FRACTURES AND FRACTURE FIXATION

“Biomechanics” is a complex and encompassing term that applies to many aspects related to orthopedic surgery, and specifically to fractures and fracture fixation. The application of biomechanical principles and concepts is essential to understand how the fracture occurred, how to best treat the injury, and how to avoid mechanical failures of the fixation construct. One must first understand the fundamental terms and concepts related to mechanical physics. This establishes the foundation that will be used to apply these concepts to the field of orthopedic surgery. The biomechanical properties of bone as well as the biomechanics of fracture healing are also essential to understand how bone is injured and how to best restore its function. Finally, understanding the biomechanical properties of common implants and failures seen with their application helps the clinician to a thorough understanding that aids in patient care.

In the study of biomechanics as it relates to fracture fixation, the fundamental mechanical question remains: Is the fixation system stable and strong enough to allow the patient early mobility before bony union is complete? This must occur without delaying healing, creating bone deformity, or damaging the

implant, and yet be flexible enough to allow transmission of force to the healing fracture to stimulate union. The common adage in orthopedics is that, “Fracture healing is a race between bony union and implant failure.” A thorough understanding of the biomechanical concepts as they relate to bone, fracture, and implants is essential for the proper treatment of patients with fractures.

BASIC CONCEPTS

Before describing the performance of fracture fixation systems, some basic concepts used in biomechanics must be understood. A *force* causes an object to either accelerate or decelerate. It has *magnitude* (strength) and acts in a specific direction, which is termed a *vector*. However complex the system of forces acting on a bone, each force may be separated into its vector components (which form a 90-degree triangle with the force). Any of several components, acting in the same or different directions, can be added to yield the net or *resultant force*. As seen in Figure 1-1, a simplified example of the hip joint shows that the forces acting about the hip include the body weight, joint reactive force, and the hip abductors. As the hip in this example is at rest, the net force must be zero; therefore, if the body weight and hip abductor forces are known, the joint reactive

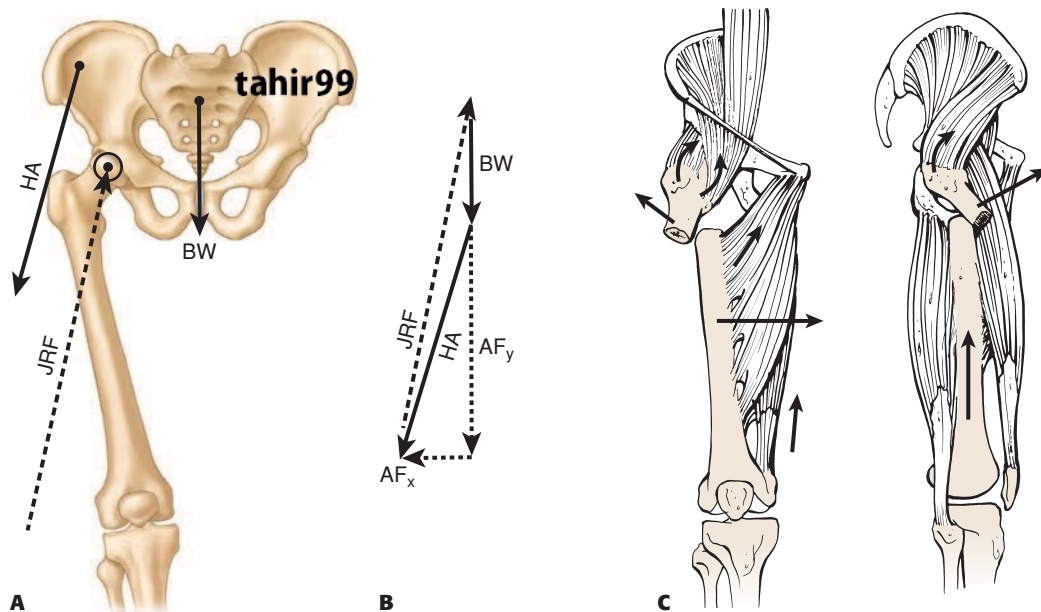

FIGURE 1-1 The force vectors acting on different parts of the body are a culmination of muscle, tendons, ligaments, and external forces. **A:** A simplified example of the force vectors acting on the hip joint. HA, hip abductors; BW, body weight; JRF, joint reactive force. **B:** Using the x and y vector components of the forces about the hip the joint reactive force (JRF) can be calculated because if the hip is at rest, the sum of all the forces should equal zero. AF_y (vertical component of HA force) AF_x (horizontal component of HA force). **C:** Understanding the forces that are applied about a fracture can help the surgeon understand the deforming forces and assist in reduction and fixation strategies.

force can be calculated using the x and y components of all the forces. Also, understanding the forces about a fracture help the surgeon to understand the deforming forces, the reduction maneuvers, as well as the proper application of implants to best stabilize the injury. Both the design of the implants as well as the application by the surgeon must be done with these concepts in mind so that they can withstand the mechanical loads applied without failure.

The two major loads acting on a long bone are those that cause it to displace in a linear direction (translation) and those that cause it to rotate around a joint center. Muscles typically cause a bone to rotate (e.g., the biceps causes the forearm to flex and supinate, the anterior tibialis causes the foot to dorsiflex). When a force causes rotation, it is termed a *moment* and has a *moment arm*. The moment arm is the lever arm against which the force acts to cause rotation. It is the perpendicular distance of the muscle force from the center of rotation of the joint. As shown in Figure 1-2, the moment or rotary force is affected not only by the magnitude of the force applied, but also by its distance from the center of rotation. In the example, two moments act on the outstretched arm. The weight carried in the hand as well as the weight of the hand and forearm rotate the arm downward, while the balancing muscle force rotates the forearm upward. Equilibrium is reached by balancing the moments so that the forearm does not rotate and the weight can be carried. Note that to achieve this, the muscle force must be eight times as large as the weight of the object, forearm, and hand because its moment arm or distance from the center of the joint is only one-eighth as long.

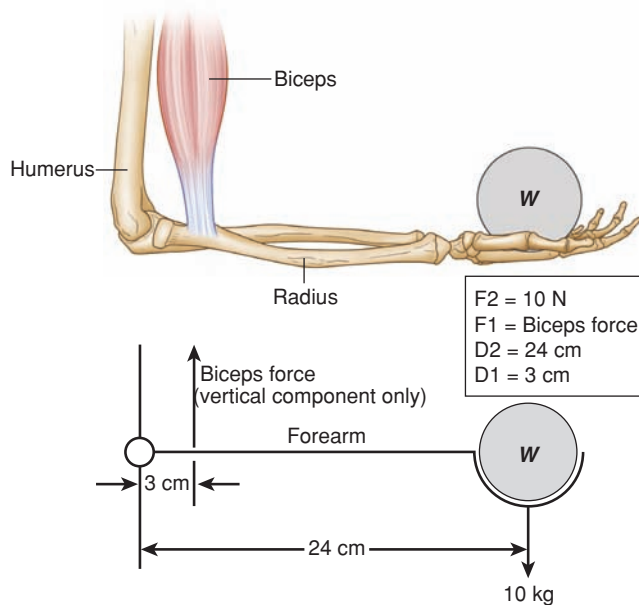

FIGURE 1-2 In this simplified example of a free body diagram, the outstretched arm is a lever and is at rest. The rotational force, or the moment, is centered about the elbow. This moment is defined as the product of the weight (object + forearm + hand) (F_2) and the distance from the elbow (d_2). This moment must be counteracted by a moment in the opposite direction. In this example the vertical component of the biceps force (F_1) is the counteractive force. The lever arm of this force is the distance from the elbow to the insertion of the biceps (d_1). The biceps force is calculated from $10 \text{ kg} \times 24 \text{ cm} = F_1 \times 3 \text{ cm}$. Thus $F_1 = 80 \text{ N}$. The biceps force is much greater than the weight of the object, arm, and hand because its lever arm is smaller.

The basic forces—compression, tension, torsion, and bending—cause the bone to behave in predictable ways. A *compressive force* (Fig. 1-3) results in shortening the length of the bone, whereas *tension* elongates it. *Torsion* causes twisting

of a bone about its long axis, whereas *bending* causes it to bow at the center. When these forces are great enough to cause the bone to fracture, it results in characteristic fracture patterns that can be recognized on radiographs. Understanding these forces

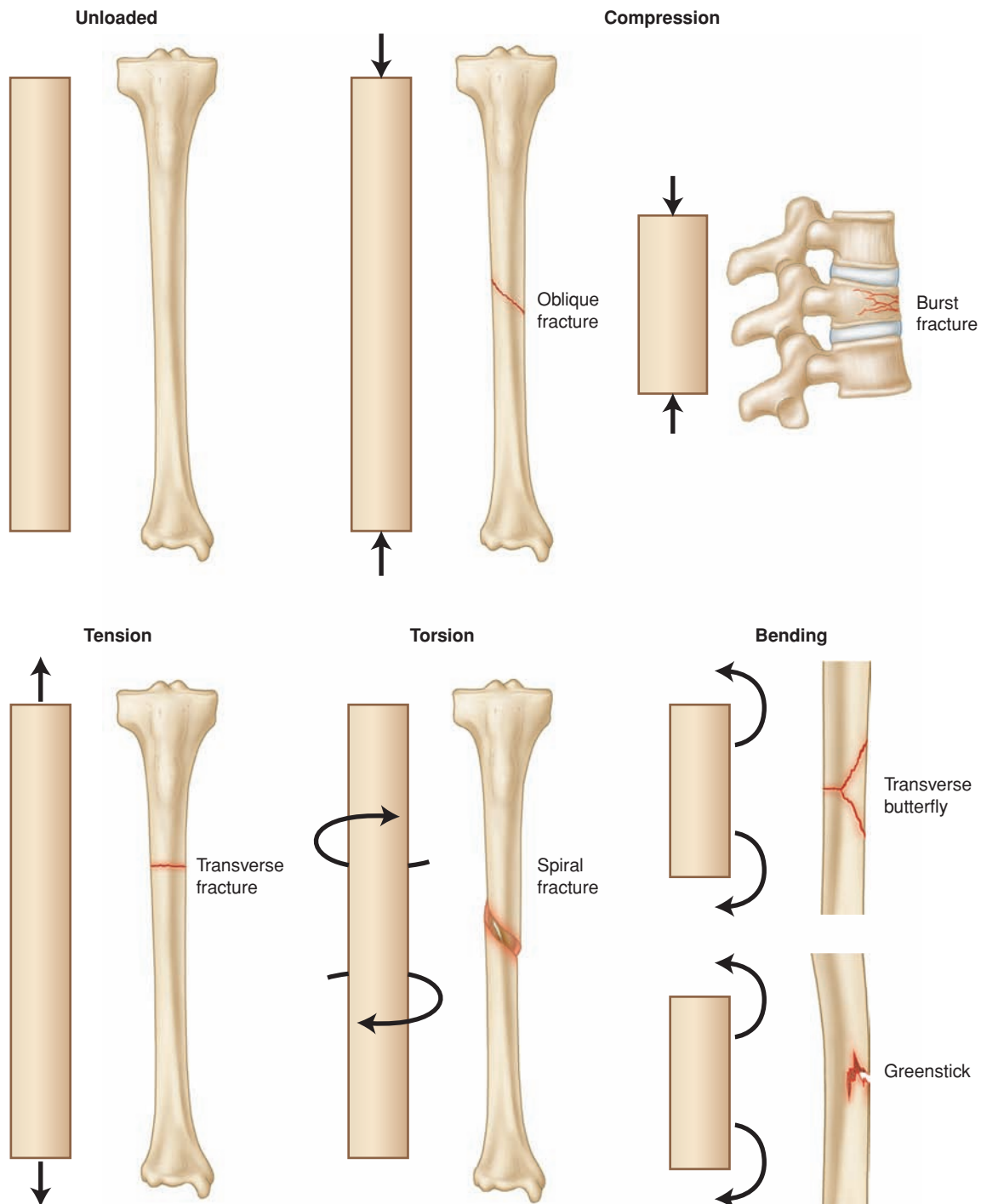

FIGURE 1-3 Basic forces: Unloaded; compression shortens length and can lead to an oblique fracture line or comminution; tension can lead to a transverse fracture. Torsional forces usually cause a spiral pattern. Bending forces cause compressive forces on one side and tensile forces on the other. This can result in a transverse fracture on the tensile side and comminution in a classic butterfly pattern on the compressive side. Bending forces can also result in incomplete or “greenstick” fractures in the pediatric population.

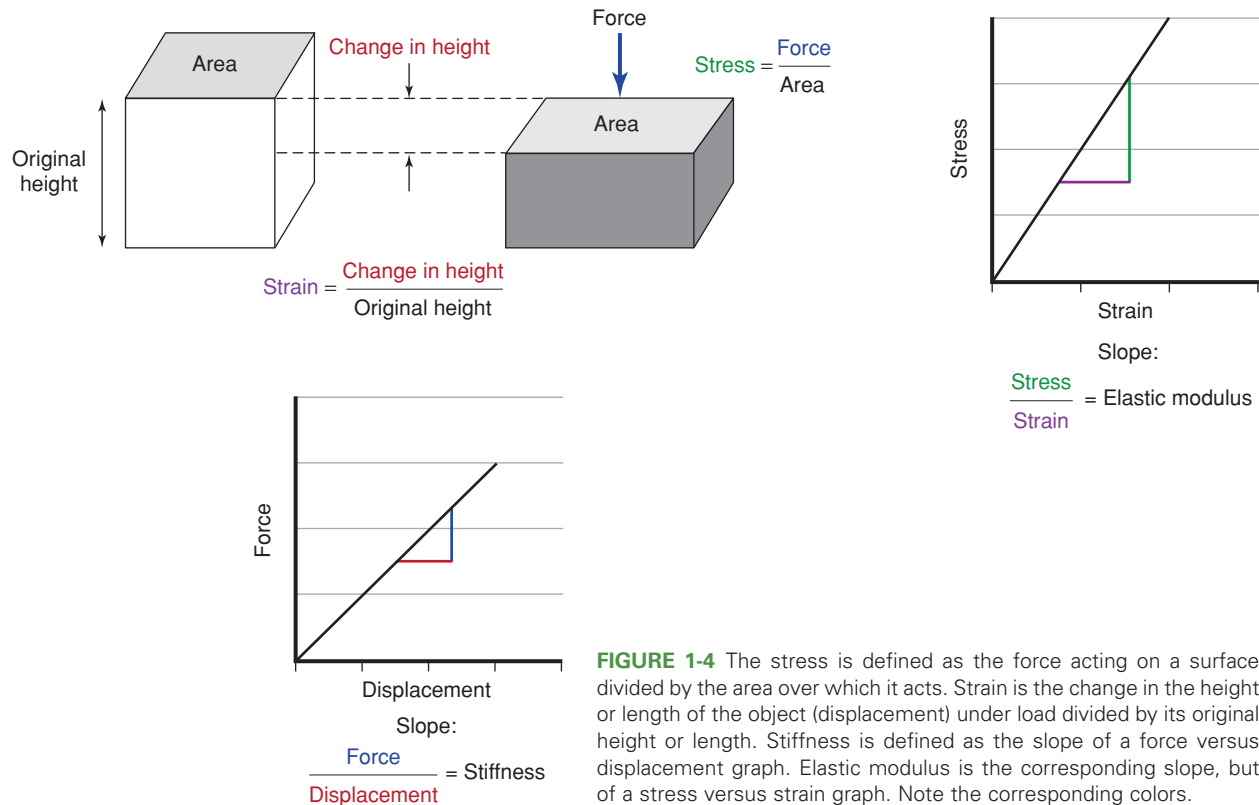

FIGURE 1-4 The stress is defined as the force acting on a surface divided by the area over which it acts. Strain is the change in the height or length of the object (displacement) under load divided by its original height or length. Stiffness is defined as the slope of a force versus displacement graph. Elastic modulus is the corresponding slope, but of a stress versus strain graph. Note the corresponding colors.

can help to understand the circumstances of the forces that occurred at the time of the fracture. Compressive forces can cause oblique fracture lines or can result in comminution and fragmentation of the bone. *Tensile* forces usually cause transverse fracture lines, whereas torsion can cause spiral fractures. Bending forces cause compressive stress on one side and tensile stress on the other side. Bending forces can also cause plastic deformation of immature or flexible bone or result in partial fractures. These partial fractures are also known as “greenstick” fractures and are usually seen in the pediatric population. In a more rigid bone, the tensile forces result in a transverse fracture line and the compressive forces cause comminution, usually in the characteristic butterfly fragment. In many cases an injury is caused by a combination of these forces and the fracture pattern may have a combination of patterns.

Stress, as shown in Figure 1-4, is simply the force divided by the area on an object over which it acts. This is a convenient way to express how the force affects a material locally. For example, when an equal force (hammer blow) is applied to both a sharp and a dull osteotome, the sharp osteotome will concentrate the same force over a smaller surface area than a dull osteotome because of the sharp edge. Therefore, the sharp osteotome will create a greater stress at the osteotome–bone interface, resulting in cutting of the bone. Just as stress is a normalized force (force per unit area), changes in length can also be normalized. *Strain* is simply the change in height or length that a material undergoes during loading, divided by its original height or length. If two plates of different lengths are both subjected to loads that lengthen the plate by 1 cm, the shorter of the two plates will

be subjected to more strain as change in length is spread over a shorter distance than it is for the longer plate.

Mechanical testing is used extensively to analyze the properties of different constructs as well as new implant designs.⁶⁷ The testing usually consists of a natural or synthetic fractured bone fixed with a certain implant in different configurations. This construct is then loaded into an apparatus that applies a specific load in either a constant or cyclic manner. Sensors can measure the forces applied to the bone as well as any deformity or eventual failure (Fig. 1-5). Depending on the purpose of the experiment the data can be collected measuring the *structural properties* of the bone–fixation construct; that is, the properties of the fixation device and the bone combined. Alternatively, the data can measure the *material properties* which relate to the properties of the substances that make up each component (bone, stainless steel, titanium). In this example, the material properties of the plate are being tested using a fracture model. The corresponding graph represents the data measured in this experiment plotted on a stress–strain graph. The force and displacement are measured and normalized to stress and strain. The initial deformation is termed *elastic* because when the load is removed, the plate will return to its original shape. This is represented by the linear portion of the graph, termed the elastic region. At some load, however, the construct becomes overloaded, entering the *plastic* range. If the load is released after loading in the plastic range but before failure, some *permanent deformation* remains in the construct. The point at which elastic behavior changes to plastic is termed the *yield point*. As previously mentioned, the slope of the stress–strain curve is the elastic (Young’s) modulus.

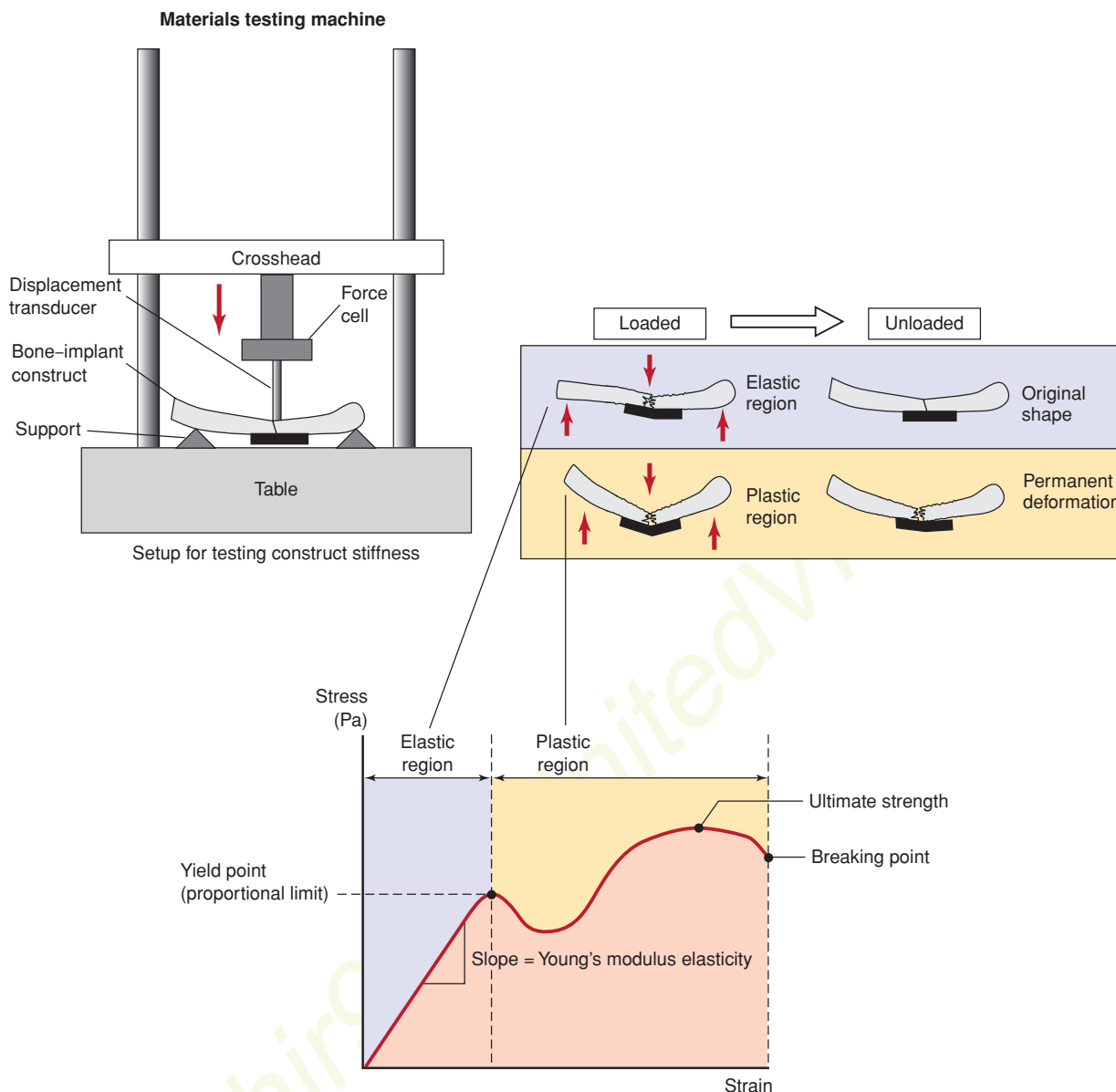

FIGURE 1-5 **Top left:** A fixation construct setup in a mechanical testing machine. In this example, a long bone is fixed with a plate and subjected to bending. **Top right:** The construct during loading in the elastic region and plastic region. **Bottom:** The resulting measurements from the testing machine, which measures stress and strain at the point of the applied load. The graph demonstrates the elastic region, in which the plate acts like a spring, returning to its original shape after the load is released; the plastic region, in which the plate may have permanent deformity; and the failure load, in which the plate fails. The area beneath the curve (*pink area*) is the toughness of the material, or the amount of energy that a material can absorb before failure.

The area under the stress–strain curve is termed the strain energy which is the energy absorbed. *Toughness* is the amount of energy that a material can absorb before failure.

The elastic range represents the working range for the fixation construct. In this region the plate is able to withstand the forces applied to it without losing its shape. The yield point defines the safe maximum functional load before the plate is permanently deformed. A third very important property, fatigue, will be discussed later.

Note that a fixation construct may have different yield points and stiffnesses for loads acting in different directions. An example is a half-pin external fixator construct applied to a tibia, with the pins oriented anteriorly–posteriorly. The stiffness is much greater in anterior–posterior (flexion/extension) bending than medial–lateral (varus/valgus) bending for this construct. Another property to consider is the *work done* in deforming a fixation construct. The product of the force applied and the distance the construct bends is defined as the work done, and is represented by the area under

TABLE 1-1 Basic Engineering Properties of Common Biologic and Implant Materials

Material	Ultimate Strength Tensile (MPa)	Ultimate Strength Compressive (MPa)	Yield Strength 0.2% Offset (MPa)	Elastic Modulus (MPa)
Muscle	0.2			
Skin	8			50
Cartilage	4	10		20
Fascia	10			
Tendon	70			400
Cortical bone	100	175	80	15,000
Cancellous bone	2	3		1,000
Plaster of Paris	70	75	20	
Polyethylene	40	20	20	1,000
PTFE Teflon	25			500
Acrylic bone cement	40	80		2,000
Titanium (pure, cold worked)	500		400	100,000
Titanium (Al-4V) (alloy F 136)	900		800	100,000
Stainless steel (316 L) (annealed)	>500		>200	200,000
Stainless steel (cold worked)	>850		>700	200,000
Cobalt chrome (cast)	>450		>50	20,000
Cobalt chrome (wrought, annealed)	>300		>300	230,000
Cobalt chrome (wrought, cold work)	1,500		1,000	230,000
Super alloys (CoNiMo)	1,800		1,600	230,000

(Ultimate tensile strength or maximum force in tension, yield strength at 0.2% offset, the strength at which the strain in the material [change in length/original length] is 0.2%, a usual standard for metals, elastic modulus, or stress/strain.)

the force–displacement graph of Figure 1-4. A material may be flexible and tough (e.g., rubber, or a child's bone that deforms but is difficult to break) or stiff but brittle (e.g., glass, elderly bone), if it cannot absorb much deformation without fracturing.

The factors that govern stiffness and yield point are the material from which the fixation device is made and its shape. A construct made of higher elastic modulus materials will be stiffer (e.g., stainless steel is stiffer than titanium) (Table 1-1). The stiffness of a construct is found by dividing the force applied by the deformation that the construct exhibited. The *elastic* (or *Young's*) modulus is determined by dividing the stress applied by the resulting strain (Figs. 1-4 and 1-5). The moduli of some common orthopedic materials are given in Table 1-1. As shown, the elastic modulus of titanium alloy is about one-half that of stainless steel; so, given two plates of the same size and shape, the titanium plate has about one-half the stiffness of the stainless steel plate. This can be important to consider when using new devices made of different materials.

Another concept is how the shape and size of an implant influences the load it can support. As shown in Figure 1-6, a typical plate used in fracture fixation is wider than it is thick. Thus, the plate is actually stiffer when the load is placed against the edge rather than the broad surface of the plate. This is because when the load is applied on the edge of the plate, the material of the plate resisting the load is distributed further away from the center (note that in this example, the mate-

rial of the plate did not change, just its orientation relative to the load applied). This concept of distribution of material is reflected in the shape property, *moment of inertia*. The moment of inertia provides a measure of how the material is distributed in the cross section of the object relative to the load applied to it. The farther away the material is from the center of the beam, the greater its stiffness. Steel I-beams were developed to take advantage of this concept; that is, gaining greater stiffness for the same amount of material. For solid cylindrical objects like rods, pins, or screws, their stiffness is related to the fourth power of their radius. As shown in Figure 1-6, for rods made of the same materials, a 16-mm diameter intramedullary (IM) rod is 1.7 times as stiff as a 14-mm rod ($(8/7)^4 = 1.7$).

A third important property of a fracture fixation construct is its ability to resist *fatigue* under cyclic loading. Load can be applied that remains below the yield point of the construct, yet creates a crack that progressively grows. This lowers the yield point of the material and the local stresses will eventually exceed the yield point and the construct will fail (Fig. 1-7). Some materials have an *endurance limit* such that they can support a certain level of load indefinitely without failure. An important aspect of fatigue performance of a fixation construct is the effect of a *stress riser*. In completely uniform materials, the stresses will be almost identical throughout the material. But typical fixation devices have holes, screw threads, and other features in which the shape changes and leads to a change of

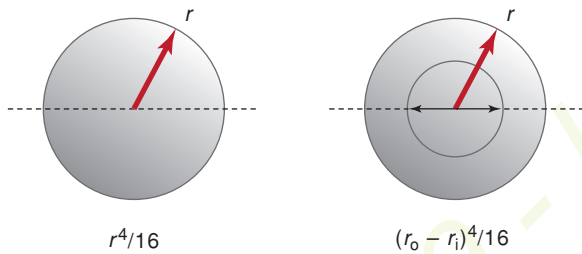
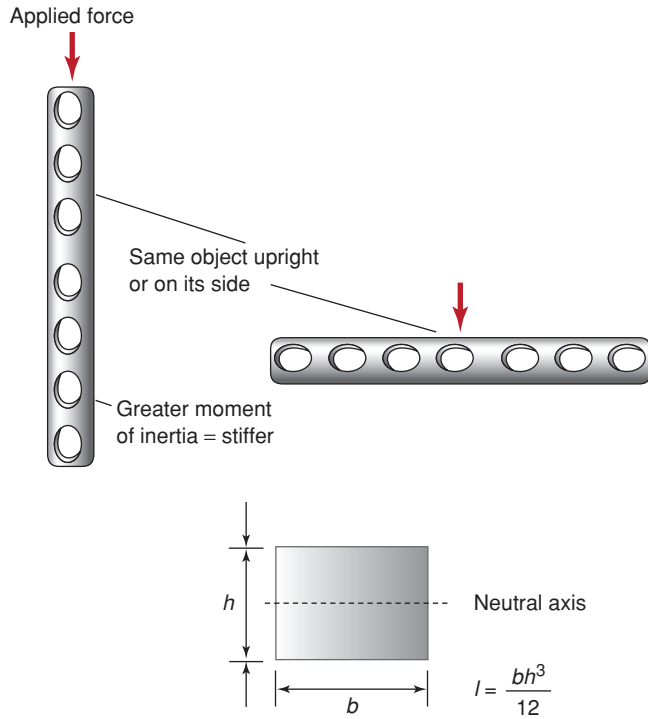

FIGURE 1-6 The concept of moment of inertia or the effect of the geometry of an object on its stiffness. **Top:** Looking at a typical plate used in fracture fixation, when the load is applied on the broader surface the plate is less stiff than when the load is applied to the narrower edge. This is because the distribution of the material is farther from the load applied. **Bottom:** The moment of inertia is a term used to describe how the material is distributed within an object. For a solid rectangular object such as a plate, the moment of inertia (I) and the stiffness increase directly with the width (b) of the plate and the cube of its height (h). For a solid cylinder, such as a pin or a screw, the moment of inertia increases with the fourth power of its radius (r). Therefore a 16-mm diameter IM rod is 1.7 times as stiff as a 14-mm rod, and 2.3 times as stiff as a 13-mm rod, if all the rods are made of the same material. For a hollow cylinder such as an intramedullary nail, the radius of the inner diameter (r_i) is subtracted from the radius of the outer diameter (r_o). The moment of inertia still increases by the fourth power.

the material properties. It is the transition points which create a stress riser. One must also take into account the interface at the end of a fixation construct. The end of the plate or rod creates an abrupt transition between the metal and bone creating a stress riser. Although this cannot always be avoided, placing the end of the implant in a high-stress area such as the subtrochanteric region of the femur can lead to periprosthetic fractures (Fig. 1-8). These fractures can be secondary to another

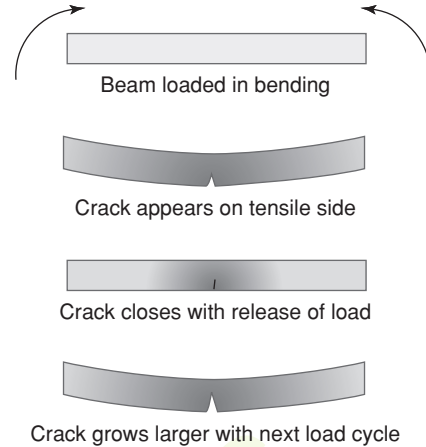

FIGURE 1-7 A stress concentrator is a region of an object in which stresses are higher than in the surrounding material. Taking the example of a fracture plate subjected to bending, the bottom surface elongates under load. In the region of highest tensile forces, a scratch starts to grow into a crack that closes when the load is released, then reopens slightly larger with the next load cycle, eventually growing to a point at which the plate fails. Crack growth is accentuated by stress corrosion, poor bone-to-bone contact at the fracture, and by loads applied by heavier patients.

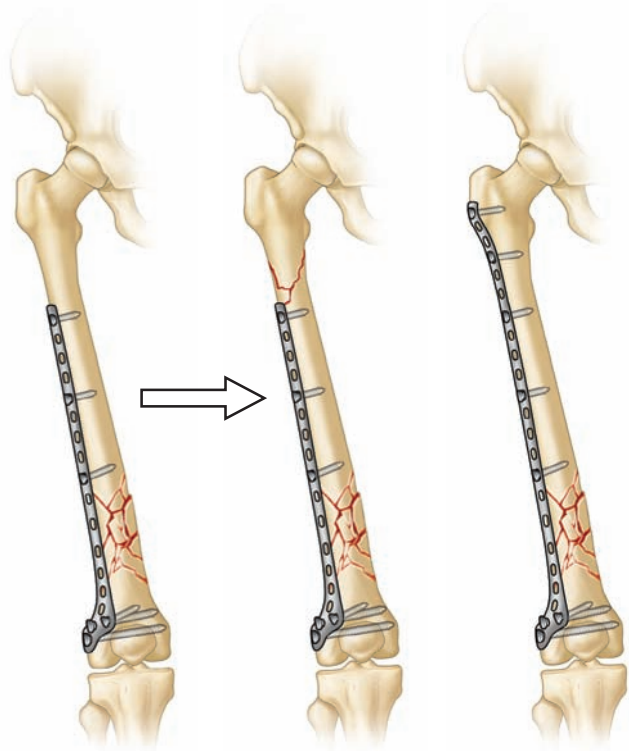

FIGURE 1-8 A stress riser at the end of a fracture construct can cause problems if it is in a region of high stress. In this example, a femoral shaft fracture is fixed using a lateral plate. If the end of the plate is in the high-stress subtrochanteric region, there is a risk that the stress riser can contribute to a periprosthetic fracture. To avoid this, a longer plate can be used to bypass the high-stress area.

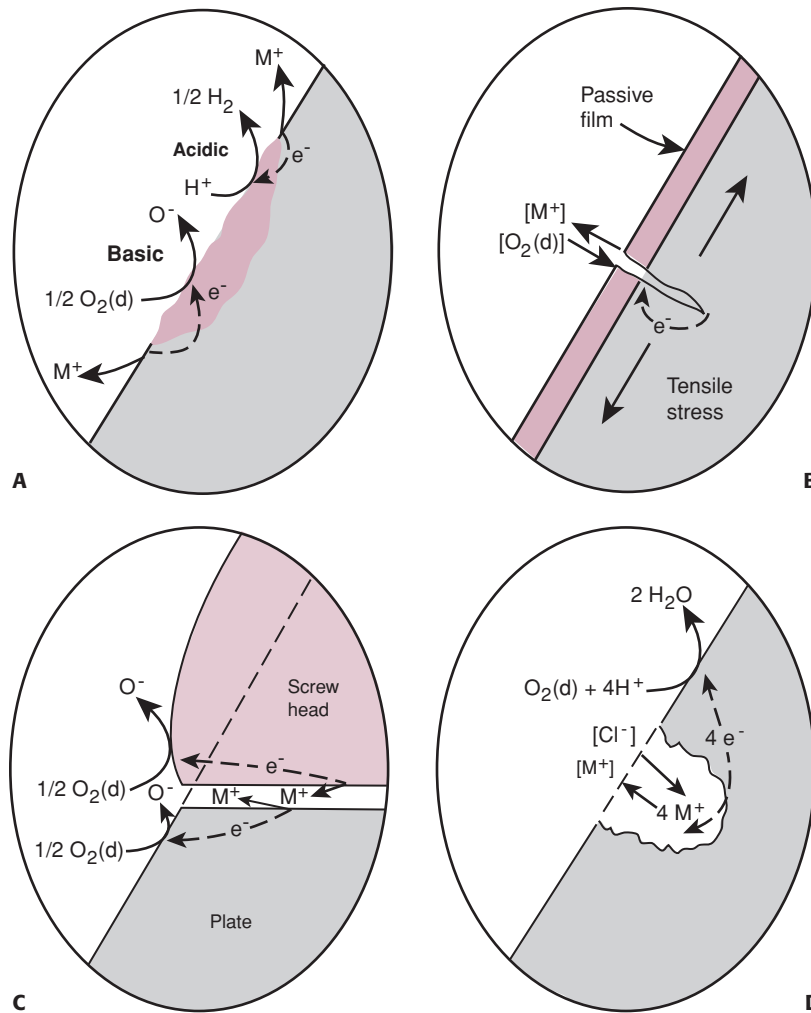

FIGURE 1-9 A: Illustration of crevice corrosion, with a local galvanic cell caused by an impurity in the surface of a plate and ions, M^+ , being released, resulting in loss of material and formation of a crevice. **B:** Stress corrosion occurs by a local galvanic cell setup between the material at the tip of the crack, which just opened and has not oxidized, and the remaining oxidized surface of the plate. The released ions enhance crack growth occurring from loading. **C:** Fretting corrosion caused by the loss of the oxide layer on the surface of a plate caused by rubbing of the base of the screw against the plate. **D:** Galvanic corrosion around a scratch or pit in the plate.²⁶

traumatic event or can be caused by cyclical loading and fatigue failure at the stress riser. Thus, in this situation a longer plate should be used to bypass the high-stress area, particularly in areas of poor bone quality.

A scratch can also cause a local small stress concentrator. When immersed in the saline environment of the body, *stress corrosion* can occur. Stress corrosion combines the effects of the local growth of the crack resulting from cyclic loading with galvanic corrosion. A *galvanic cell* describes a local environment in which electrons flow from the more negative to the more positive material when immersed in a liquid conductor (saline, in this case) (Fig. 1-9). Material is actually removed from the more negative electrode, such as the surface of the plate during galvanic corrosion. In a fixed fracture, the dissimilar materials are the surface of the plate (e.g., stainless steel), which creates an oxide surface coating, and the same material exposed by the fatigue crack that has not yet developed the oxide film. The conductive fluid is the blood and saline found in the surrounding tissues. Galvanic corrosion can accelerate the failure of an implant, even when the implant is loaded well below its yield point, by increasing the rate at which the crack grows. This occurs because in addition to the mechanical propagation at the

site of the crack, material at the crack is being removed by the corrosion process. Another mechanism of corrosion, termed *fretting*, results when the surfaces of two implants rub together, such as the head of a screw against the surface of the plate through which it passes. *Crevice corrosion*, which is not common in modern orthopedic materials, results from small galvanic cells formed by impurities in the surface of the implant, causing crevices as the material corrodes.²⁶

Another basic property is *viscoelasticity* (Fig. 1-10). Biologic materials do not act as pure springs when load is applied to them. A spring deforms under load and then returns to its original shape when the load is released. For example, if a load is applied to a tendon, and the load is maintained for a period of time, the tissue will continue to deform or *creep*. This is the basic principle behind stretching exercises. Under a constant load, a metal fixation plate will deform and remain at that deformation until the load is removed (elastic behavior). In contrast, the tendon both deforms elastically and creeps, exhibiting both viscous and elastic behavior. This property has important implications for certain types of fixation, especially those that rely on loading of soft tissues, such as in certain types of spinal fixation (to be discussed later).

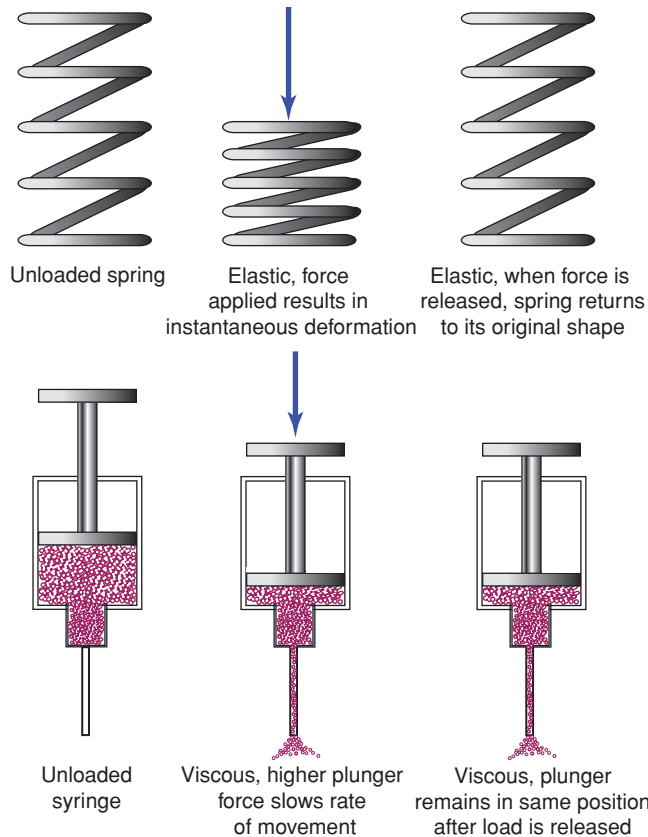

FIGURE 1-10 Viscoelastic response in a biologic tissue can be explained by considering and combining the properties of two devices, a simple spring and a fluid-filled syringe. The elastic or spring component instantly compresses when a load is applied to it. When the load is released, the spring returns to its original shape. When a load is applied to the viscous component, represented by the syringe, fluid is forced out of the needle. If the load is released, the plunger does not return, but remains in its final position, representing the creep property of the tissue. Further, if the force is applied to the plunger more rapidly, there is greater resistance to motion, explaining the increased stiffness of tissue to increased rates of loading. Combinations of these simple components can be used to describe the mechanical properties of biologic tissues.

A second characteristic of viscoelastic behavior is *loading rate dependence*. In simple terms, stretching a soft tissue can be thought of as stretching two components, an elastic one and a viscous one, which make up that tissue. For example, consider a spring connected in series to the handle of a syringe. When a compressive force is applied, the spring instantly compresses, representing the elastic response of the tissue. The syringe plunger starts to displace and continues as it pushes fluid through the orifice. If the force is held constant, the plunger will continue to move, representing the viscous creep of the tissue. If the compressive force is applied slowly, the syringe handle offers little resistance. As the rate of force application increases, the resistance of the syringe to motion increases. This represents the increase in stiffness of the tissue at higher loading rates. Simply put, the stiffness of the tissue depends upon the rate at which the load is applied.

A well-known example of loading rate dependence relates to the failure of ligament and bone. At low loading rates, the ligament is weaker than the bone and the ligament generally fails in the midsubstance. At higher loading rates, the ligament becomes stiffer, and failure may occur by avulsion of the bony attachment of the ligament. *Stress relaxation* occurs if the applied force, instead of increasing, is held constant. As the fluid flows out of the syringe, without further movement of the plunger, the internal force decreases. These three properties—creep, stress relaxation, and load rate dependence—make up the basic tissue viscoelastic properties. It should be appreciated that the model used in this discussion is a simple linear series model, for explanation purposes only. Nevertheless, more complex models using combinations of these basic components have successfully described the observed properties of tissues. Another example of tissue viscoelasticity, besides tendon and other soft tissues, is found in trabecular bone (e.g., as found in vertebrae). In this case, the trabecular structure acts as the spring component, whereas forcing the interstitial fluid through the porous matrix as the trabeculae deform represents the viscous component. Under higher loading rates, there is resistance to flow, increasing the internal pressure and therefore the stiffness of the structure. These effects have been observed at high loading rates, such as during fracture (Fig. 1-11).³⁴

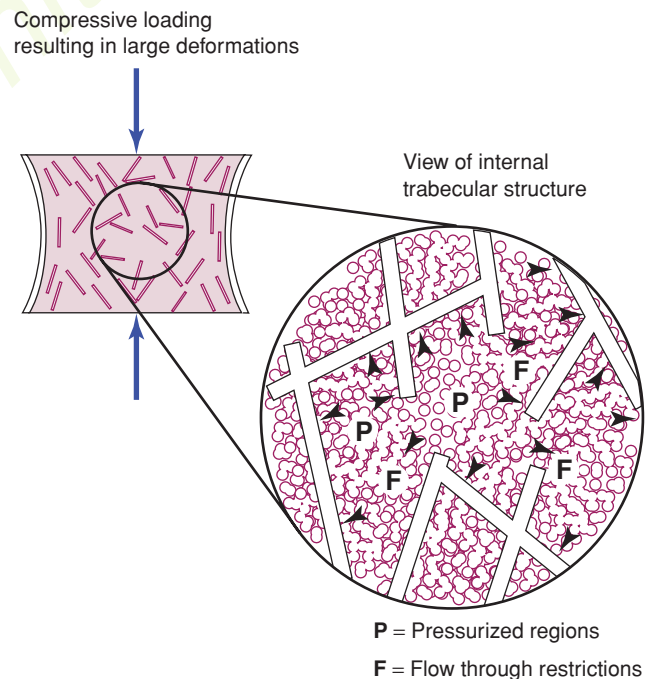

FIGURE 1-11 The trabecular bone possesses some features of the spring and syringe viscoelastic model described in Figure 1-10, although it should be appreciated that this is an idealized model. The trabecular structure acts as the spring element. At higher loading rates, the interstitial fluid resists flowing through the trabecular spaces, causing increased internal pressure and greater bone stiffness. This anatomical feature allows vertebrae and the metaphyseal ends of long bones to resist dynamic loads caused by rapidly applied forces.³⁴

TABLE 1-2 Definitions of the Units Used to Describe the Basic Properties of Fracture Constructs

Force, newtons (N)	1 N = 0.2246 lbs
Displacement, millimeters (mm)	
Stress, pressure, modulus, megapascals (MPa)	with 1 MPa = force of 1 N / area of 1 mm ²
Modulus	= stress / strain, in which stress units are MPa; strain has no units
Strain (no units); strain	= change in length (mm) / original length (mm)

In summary, bones and joints can be subjected to various forces, but these forces can be resolved into basic components that create tension, compression, shearing, twisting, and bending. These forces cause internal, compressive, tensile, and shear stresses in the tissue. The stiffness of a fixation construct used to stabilize a fracture describes how much it deforms under a given load acting in a specific direction. Stiffness may vary with direction and is highly dependent on the shape of the fixation construct. The effect of shape is described by the moment of inertia. In combination with the moment of inertia, the elastic modulus of the material describes how stiff the fixation will be under load, and its ability to withstand the forces of, for example, the patient's weight during ambulation. Failure of fixation results not only from loading above a construct's yield point but also as a result of repetitive stress. Repetitive loading can

cause the growth of a crack at a stress concentrator, and can be significantly accentuated by corrosion when the implant is immersed in bodily fluids. Biologic tissues behave viscoelastically, that is, they creep under constant load, stress-relax when the elongation is fixed, and increase in stiffness as the rate of load application increases. In this chapter, these mechanical properties are described in basic units of measurements, defined in Table 1-2.

BIOMECHANICS OF INTACT AND HEALING BONE

Bone has a hierarchical structure. As shown in Figure 1-12, the lowest level of the structure consists of single collagen fibrils with embedded apatite crystals. At this level of structure, changing the collagen-to-mineral ratio has a significant effect on the elastic modulus of the bone,^{32,34,41} which decreases with loss of minerals (Fig. 1-13). This is important from a fracture-healing perspective because mineralizing healing callus goes through phases of increasing mineral density and corresponding increased modulus as healing occurs. At the next level of structural organization, the orientation of the collagen fibrils is important.^{9-12,57-59} As demonstrated in Figure 1-14, the orientation of its fibers affects the ability of the bone to support loads in specific directions. During fracture healing, the callus initially starts as a disorganized random array of fibers, which progressively reorganize to become stiffest along the directions of the major applied loads (body weight and muscle forces) to which the bone is exposed. At the next level, the density of the haversian systems affects bone strength. It has been repeatedly demonstrated that a power law relationship

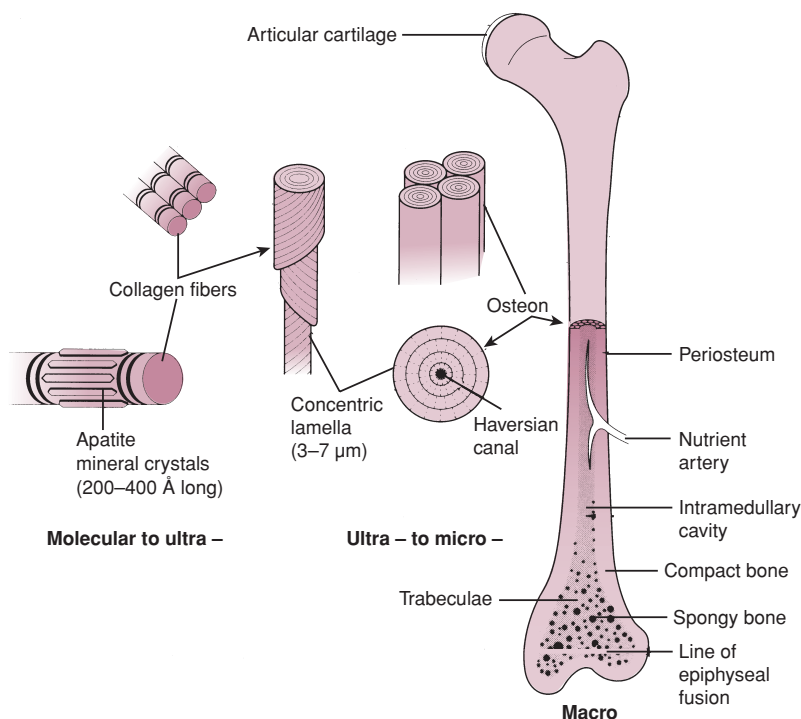

FIGURE 1-12 The hierarchical structure of bone is demonstrated. At the lowest level of organization, the ratio of mineral crystals to collagen fibrils determines the elastic modulus of the combined material, as shown in Figure 1-13. At the next level, the fiber orientation is important in determining the difference in strength of bone in different directions. At the final level, the lamella of bone fibers form haversian systems that, particularly in cortical bone, are oriented in the direction of the major loads the bone must support.

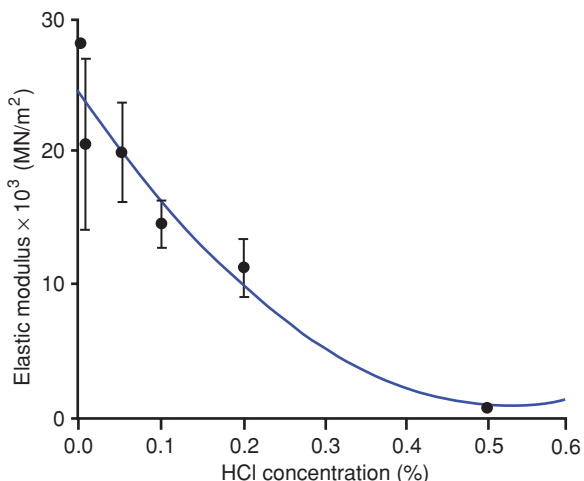

FIGURE 1-13 Elastic modulus of bone samples tested in tension after exposure to different concentrations of HCl. Greater HCl concentration progressively demineralizes bone, ultimately leaving only collagen. This diagram illustrates the contribution of bone mineral to the tensile elastic modulus of the whole bone.³²

exists between bone density and strength at this level of structure (Fig. 1-15). This means that as bone density decreases, its strength decreases as the square of its density (as density decreases by half, strength decreases by a factor of four). This forms the basis for predicting changes in bone strength as a result of conditions such as osteoporosis. Similarly, the modulus changes with bone density by a power of between two and three.^{20,22,31,37,64} Noninvasive measures of bone density such as quantitative computed tomography (QCT) have been shown to have a significant predictive relationship with bone strength.^{2,45,46,108}

Several additional factors can affect the strength of the bone. As discussed previously, bone is a viscoelastic material

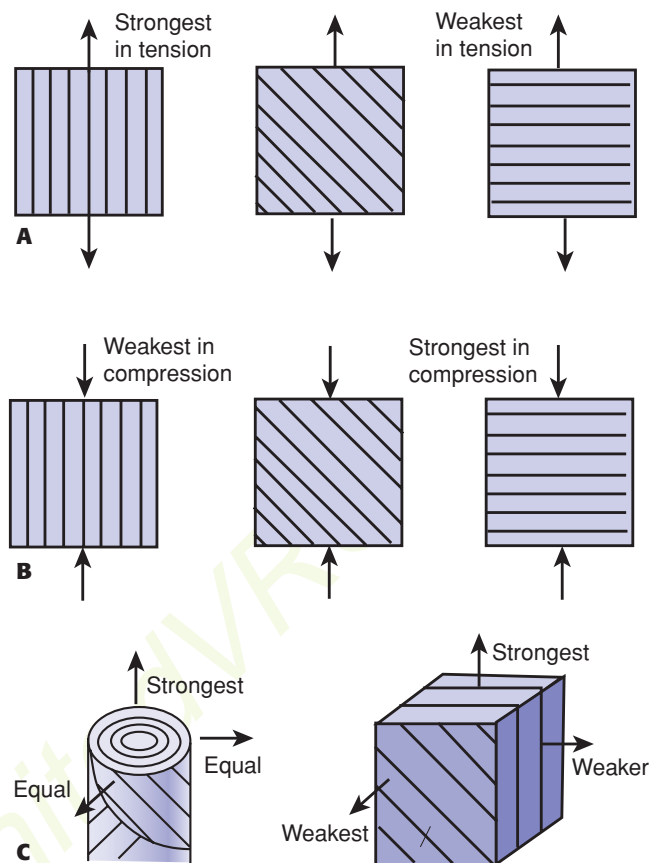

FIGURE 1-14 Effects of collagen fiber direction on the resistance to loads applied in different directions. **A:** Under tensile loading, the strongest arrangement is having the collagen fibers parallel to the load. **B:** Under compressive loading, the strongest arrangement is having the collagen fibers perpendicular to the load. **C:** In bone that must accommodate different loading directions, the arrangement of the haversian system produces one strongest direction along the axis, with approximately equal strengths in other directions.⁵⁸

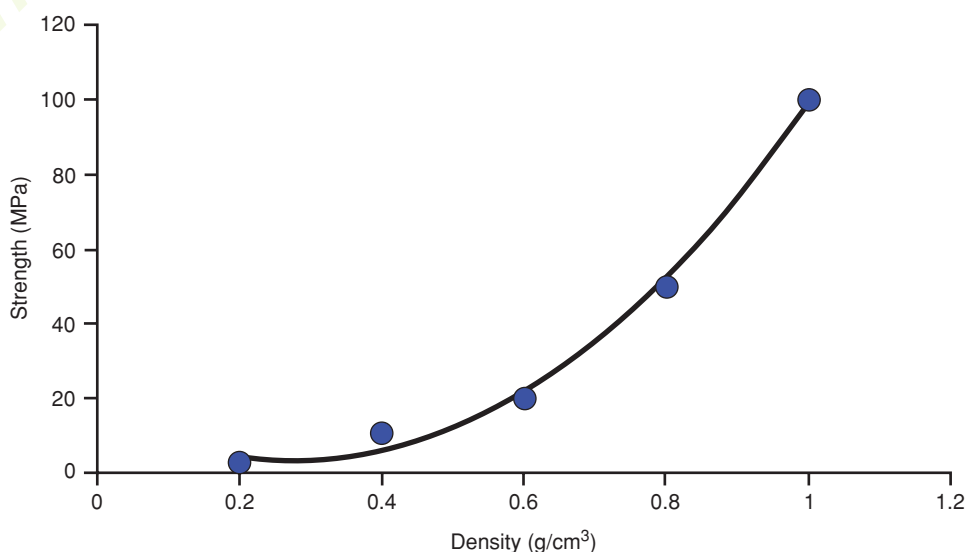

FIGURE 1-15 The relationship of trabecular bone density to compressive strength and modulus demonstrates a power law relationship, so that these properties decrease by a factor of about four when density decreases by half.³⁴

whose strength and modulus both increase as loading rate increases (e.g., in fracture impact loading as compared with normal ambulation).^{31,40,44,42,112,172} The geometry of bone, specifically the size of the cross section and thickness of the cortex, affects its moment of inertia and therefore its strength.¹³⁰ Age also affects bone properties. The bending strength and modulus increase as bone mineralizes and matures from childhood to adulthood and slowly decrease thereafter,^{44,45,166} and the capacity to absorb impact energy decreases with age⁴³ as bone becomes more brittle. Defects or holes in bone (e.g., from drilling for screws) also affect its strength.^{29,32,49,102,111} The torsional strength of bone decreases as the diameter of the hole or defect increases (Fig. 1-16). As the hole increases in size to 30% of the diameter of the bone, bone strength decreases

to about 50% of that of the bone without a defect. An important consideration, applicable in the resection of bone (such as in the removal of a tumor), is the shape of the hole or defect left after tumor removal. Leaving a hole with square corners significantly decreases bone strength compared with the same hole with rounded corners, because the square corner is a large stress concentrator. Oval or circular holes, although themselves still stress risers, do not contribute the additional effect of the sharp corner.³⁶ Table 1-3 summarizes the strength of cortical and cancellous bone material as well as the ultimate strengths of various whole bones.

As a fracture heals, its strength is affected by changes in its mineral content, callus diameter, and fiber organization, as discussed previously. The initial callus forms from the periosteal

TABLE 1-3 Mechanical Properties of Bone Material and Whole Bones in Different Loading Directions

Bone Type	Load Type	Elastic Modulus ($\times 10^9$ N/m ²)	Ultimate Stress ($\times 10^6$ N/m ²)	Reference
Cortical	Tension	11.4–19.1	107–146	57 58 93 172
	Compression Shear	15.1–19.7	156–212 73–82	44
Cancellous	Tension	~0.2–5	~3–20	34
	Compression	0.1–3	1.5–50	166 64
	Shear		6.6 \pm 1.7	157
Bone Type	Loading Direction and Type		Ultimate Strength	Reference
Cervical spine	Axial compressive impact		980–7,400 N	93
	Extension		57 N m	
	Flexion		120 N m	
	Lateral bending		54 N m	
Lumbar spine	Axial compressive impact		1,400–9,000 N	22 37
Sacroiliac joint	Axial compressive impact		3,450–3,694 N	
Femoral neck	Lateral to medial at trochanter		1,000–4,000 N 725–10,570 N	2
	Vertical impact at femoral head			103 155
Femur	Torsion		183 N m	
	From impact at knee along axis		6,230–17,130 N 21.2–31.3 N m	
	Three-point bending, posterior			
Patella	Impact perpendicular to anterior		6,900–10,012 N	
Tibia	Axial torsion		101 \pm 35 Nm	
Foot and ankle	Impact perpendicular to sole		4,107–6,468 N	15 63

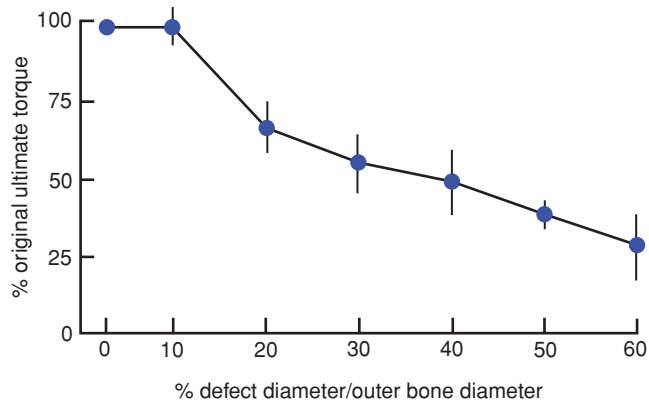

FIGURE 1-16 The relationship of ultimate torque (failure torque) of a long bone to the diameter of the hole divided by the outer diameter of the bone. There is no change in ultimate torque until the defect size increase beyond greater than 10% of the diameter of the bone.⁴⁹

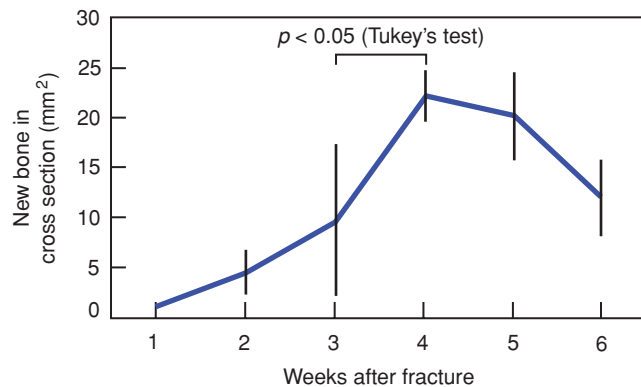

FIGURE 1-18 Changes in the cross-sectional area of a healing femoral fracture, which peaks and slowly decreases. There is a similar increase in the mineral content. (The data come from rats, which heal more rapidly than humans, indicated by the 4-week time to peak mineralization.)⁸

surface outward, which is beneficial mechanically, because as the outer diameter of the healing area enlarges, its moment of inertia and therefore its initial stiffness both increase, as shown in Figure 1-17.¹²⁸ The cross-sectional area increases progressively as shown in Figure 1-18, as does the mineral content of the callus.⁸ The mechanical results of these bony changes (as the fracture heals) are shown in Figure 1-19. From torsional tests of healing rabbit long bones, progressive increases were observed in stiffness and peak torque to failure with time.¹⁶⁸ Interestingly,

in that experiment, the stiffness appeared to reach normal values before the peak torque to failure, showing that stiffness and strength are related, but not directly. Figure 1-19 shows that beyond 4 weeks (in rats, whose bones heal rapidly), the cross-sectional area starts to decrease as the bone remodels to normal shape, whereas the bone tissue continues to mineralize.

Age also plays a very important role in the healing of bone. Increased osteoclast activity, as well as less robust osteoid and vascular proliferation, impairs the healing process.¹¹⁶

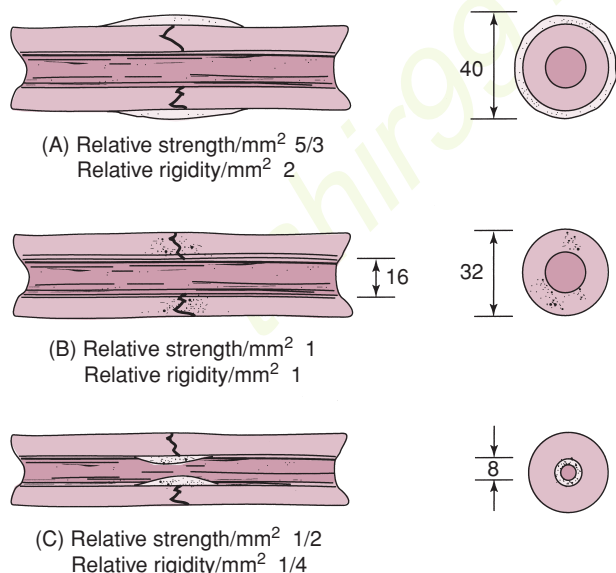

FIGURE 1-17 A comparison of the moments of inertia and resulting strengths when fracture callus is located (A) on the outer surface, (B) on the bone surfaces, or (C) in the medullary canal. The strength and rigidity are significantly increased when the callus is located over the periosteal surface, compared to within the medullary canal.¹²⁴

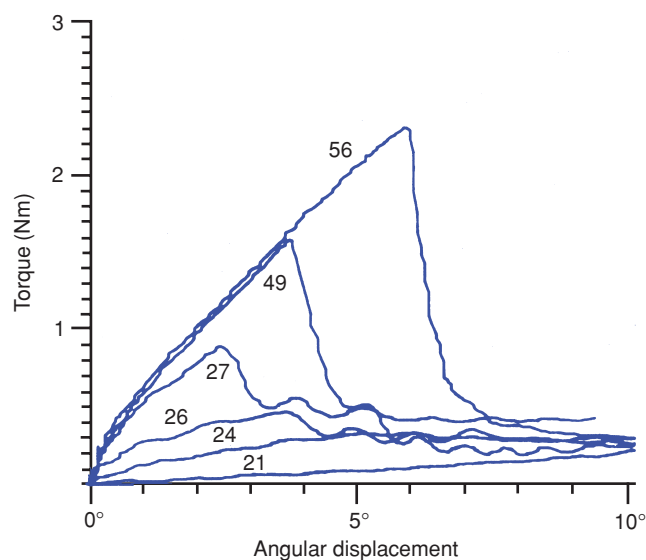

FIGURE 1-19 A comparison of superimposed torque–angular displacement plots taken from experimental long bones at different stages of healing shows the significant increase in both stiffness and peak torque to failure with increased duration of healing. Numerical values are time in days post fracture in rabbits.¹⁶⁸

Although the development of modern orthopedic implants and techniques help to increase bony fixation and mechanical stiffness, which can improve healing results, the biology of aging is the main culprit.

The mechanical environment created by the fixation system along with the available blood supply affects the type of tissue formed in a healing fracture. The theory of interfragmentary strain attempts to relate the types of tissues formed to the amount of strain experienced by the tissue between the healing bone fragments.¹²⁸ This theory is a simple representation and cannot describe the complex stresses that the tissue is exposed to during actual healing. Nonetheless, within the limitations of the theory, when large strains occur in the tissues between the healing bone surfaces, granulation tissue is formed. Intermediate-level strains produce cartilage and small strains result in primary bone healing or direct deposition of bone tissue with limited callus formation.

Among the limitations of this theory, one should recognize that zero strain does not correlate with maximum bone formation. Load and some resulting strain are necessary within the healing fracture to stimulate bone formation. In a study in which controlled daily displacements in compression were applied to healing long bones using an external fixator, and the bone mineral content of the healing fracture was measured with time, there was an optimal displacement above or below which less mineral was created in the fracture callus (Fig. 1-20).¹⁶⁷ Furthermore, compression, rather than tension, is the preferred direction of loading.¹⁶ Fracture fixation constructs of different stiffnesses within a certain range produce healed fractures with similar mechanical properties, although they may reach this endpoint by different biologic routes. In a study of femoral fixation using IM rods of either 5% or 50% of the torsional stiffness

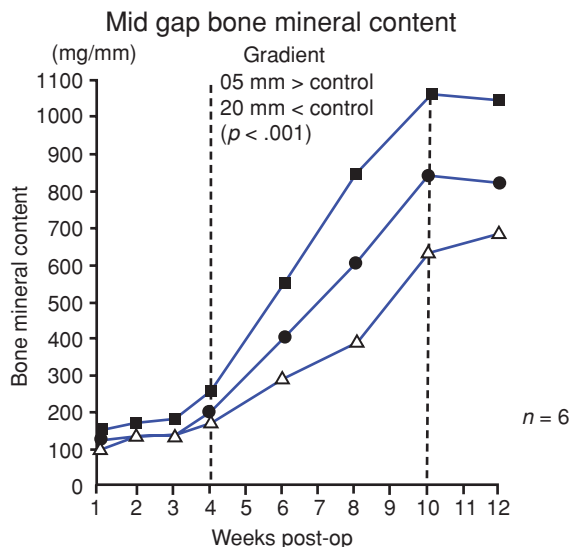

FIGURE 1-20 The effect on bone mineral of different cyclic displacements applied daily within a healing fracture (upper curve, 0.5 mm; middle curve, 1 mm; lower curve, 2 mm for 500 cycles/day). This shows that some displacement (in this experiment, 0.5 mm) stimulates bone formation, but that greater displacements (1 mm and 2 mm) do not enhance bone formation. These results point to an optimal range of displacements for maximum bone formation.¹⁶⁷

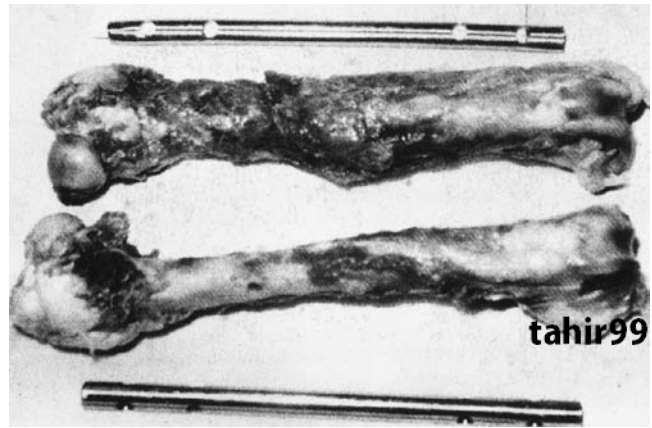

FIGURE 1-21 A comparison of the different healing responses of dog femurs with midshaft fractures fixed with **(top)** IM rods of 5%, or **(bottom)** 50% of the torsional stiffness of the intact femur. The femurs fixed with rods of lower stiffness produced more callus as additional stabilization against functional loads, but there was ultimately no difference in the mechanical properties between the femurs fixed with rods of different stiffnesses.¹⁷¹

of the intact femur, the femora fixed with the lower stiffness rods produced an abundance of stabilizing callus, as opposed to the femora with more rigid fixation; see Figure 1-21. In both cases, however, the mechanical properties of the healed fractures were ultimately similar.¹⁷¹ With the development of newer implant designs and advent of locked plating the question of excessive construct stiffness has been raised. Although compression at the fracture site, coupled with rigid fixation, is desirable in the case of anatomical reduction, for comminuted fractures rigid fixation may lead to the development of non-union. The overzealous use of locking implants to combat the poor fixation in weak bone may also cause the implant–fracture construct to be too stiff for optimal healing. Finding the correct amount of stiffness of the construct, which will in turn maximize fracture healing, is still an active area of research.^{27,65,66}

In summary, several factors affect the strength of bone and healing fractures. Increasing mineral content increases fracture stiffness. Callus that forms on the periosteal surface is beneficial in increasing the moment of inertia and therefore the stiffness of the fractured region. Healing fractures exhibit several stages, with the return of stiffness followed later by peak load to failure normalizing. Bone will heal within a range of mechanical environments. To a certain extent, healing bone will compensate for more flexible fixation by forming a greater quantity of fracture callus; however, there is a range of loading of a healing callus sufficient to stimulate bone formation, which increases as the callus matures.

BIOMECHANICS OF BONE FRACTURE

To appreciate why bone fractures in certain patterns, one must understand that, as shown in Table 1-3, the bone is weakest in tension and strongest in compression. Therefore, when a force creates tensile stresses in a particular region of a loaded bone, failure will generally occur first in that region. The simplest example, shown in Figure 1-22, is the transverse

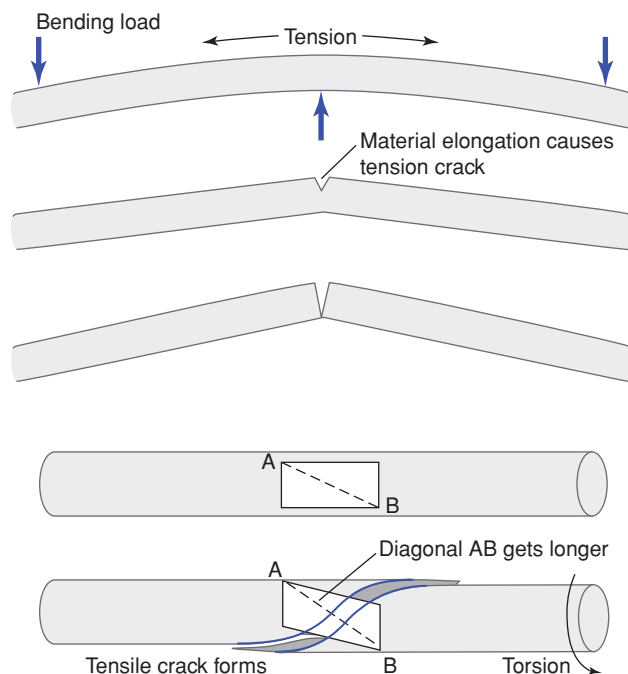

FIGURE 1-22 **Top:** A transverse fracture is created by the progressive tensile failure of bone material starting from the convex surface in which elongation, and therefore, stress is greatest, with the crack progressing to the concave side. **Bottom:** A spiral fracture is created by progressive failure in the tension of fibers on the bone surface along the diagonal that elongates as the material on the surface distorts when torque is applied. (A rectangle on the surface becomes a parallelogram, with one diagonal elongating. The fracture will be transverse to the diagonal.)

fracture created in a long bone subjected to pure bending. In this example, the upper, convex surface undergoes the greatest elongation and is subjected to the largest tensile stresses and subsequent failure, indicated by a cortical crack. The crack then progresses transversely through the material, and layers just below the outer layer become subjected to high tensile stress until they fail as well. In this manner, the crack progresses through the bone transversely until a complete fracture occurs. The concave surface is subjected to compression, so the crack does not initiate there. A second example is the fracture line or crack that occurs when a bone is subjected to torsion or axial twisting. In those cases, a spiral fracture results. Consider, as shown in Figure 1-22, a rectangular area on the surface of a long bone that is loaded in torsion. The rectangle distorts as the bone twists, with one diagonal of the rectangle elongating and the other shortening, depending on the direction of the twist. A crack will form perpendicular to the diagonal that is elongating (or under tension), and progresses around the perimeter of the bone resulting in a spiral fracture. The region of the bone with the smallest diameter is usually the least stiff region, resulting in the greatest distortion of the surface and is generally the location of the fracture. This explains why torsional fractures of the tibia often occur in the narrow distal third.

A compressive load results in the failure of cortical bone by shear, indicated by slippage along the diagonal, because

the bone is weaker in shear than in compression (Fig. 1-23). At very high loads, such as during impact fractures, crushing or comminution of bone also occurs, especially at the weaker metaphyseal ends of a long bone. The trabecular bone at the metaphyseal ends is weaker in compression than the diaphyseal cortical bone is in shear. Because of this, it is unlikely that shearing failure will occur in the diaphysis caused by pure compressive forces. The butterfly fracture (Fig. 1-23) results from combined bending and compression. Bending load causes the fracture to start to fail in tension producing a transverse crack, but as the crack progresses and the remaining intact bone weakens, it starts to fail in compression, causing an oblique (shear) fracture line. As the ends of the failing bone are driven together, a third fragment—the butterfly—may result as the oblique fragment splits off. The production of a butterfly fragment probably depends on the timing and magnitude of the two basic applied loads: compression and bending.

Aging, especially with osteoporotic changes, alters both the force required to fracture the bone and the types of fractures that occur. As shown in Figure 1-15, trabecular bone's stiffness varies with the cube (third power) of its density and its strength approximately with the square of its density.³⁴ Bone mass normally peaks around age 25 to 30 years and decreases up to 1% annually thereafter. If the density of the trabecular bone is decreased by 30% in a 60- to 70-year-old as a result of osteoporosis, the bone compressive strength is about half of that of a 30-year-old. Typically, fractures as a result of osteoporosis occur in the vertebrae, the distal radius, and the femoral neck. In addition, osteoporosis changes the cross-sectional shape of long bones, decreasing the thickness by increasing the endosteal diameter while causing the periosteal diameter to increase. If cortical outer diameter—for example, in the femur—increased and cortical thickness decreased at the same rate, the moment of inertia of the bone cross section would be larger. That is why large-diameter thin tubing can be substituted for smaller-diameter thicker tubing in structures (e.g., sailboat masts), saving weight, while not sacrificing strength. However, in the femur, the inner surface of the cortex also becomes more irregular and porous, decreasing its material strength. A common result of loss of femoral bone mass combined with other factors, such as poor balance, is a hip fracture (usually resulting from a fall).¹

Auto crashes are a common cause of high-energy fractures, and some particular mechanisms have been observed over time. Fracture of the calcaneus, talus, or pilon can occur through a combination of the foot being forced against the brake pedal by the weight of the occupant during a high-speed frontal collision, or in combination with the floor pan of the auto crushing into the space in which the foot resides.¹³⁴ Drivers who were braking during a crash were shown to be much more likely to injure their right foot compared with their left foot.¹⁵ If the Achilles tendon applies load to resist the forced dorsiflexion of the foot on the brake pedal, the combination of these two loads may cause three-point bending loading of the calcaneus, with the posterior facet of the talus as the fulcrum. A crack initiates on the plantar or tensile side of the calcaneus and a tongue-type calcaneus fracture can occur. Inversion or eversion, in which

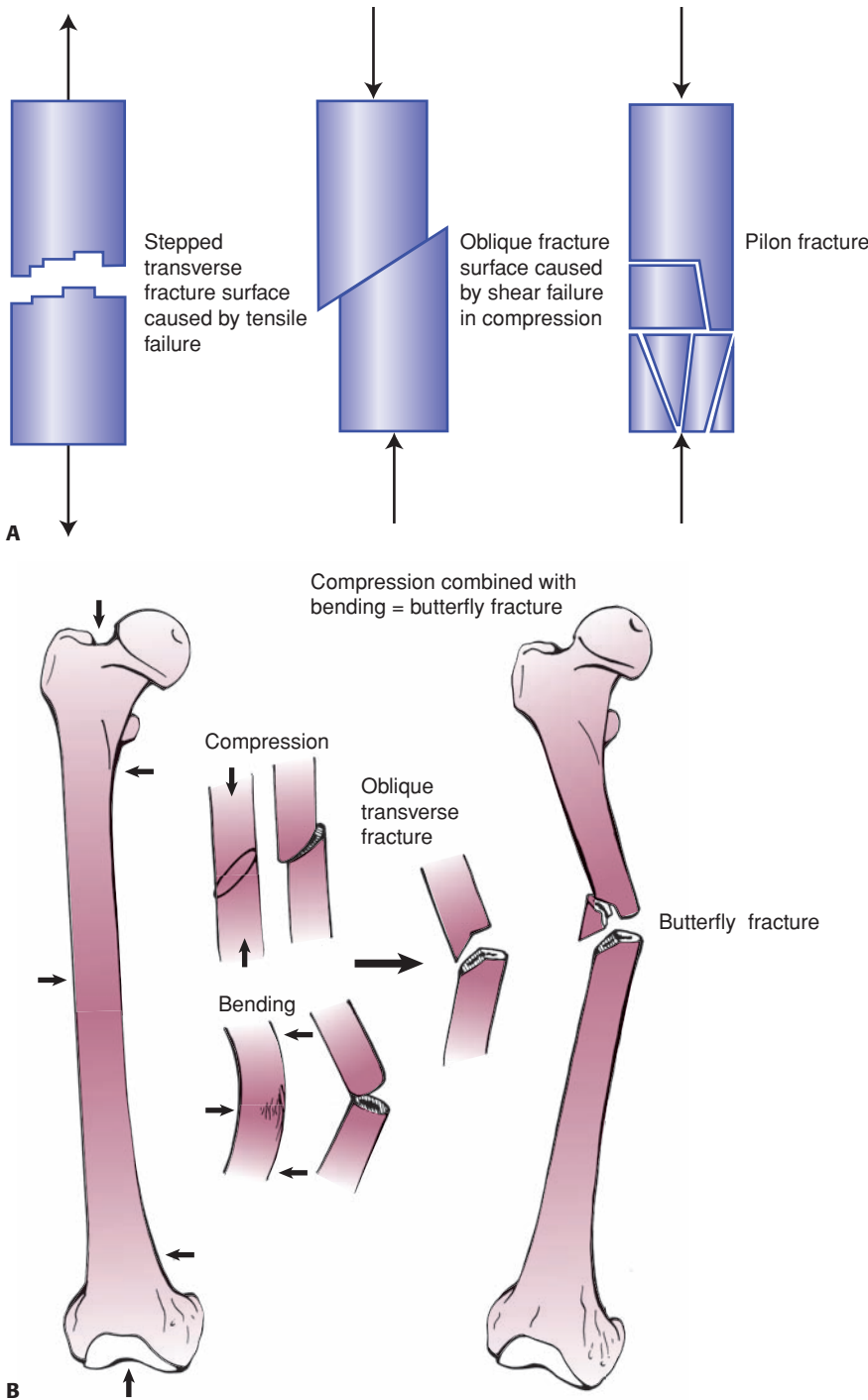

FIGURE 1-23 A: Left: Tensile fracture causes a stepped surface as fibers pull apart. The crack progresses, then steps to an adjacent region in which failure continues. **Right:** Pure compression of cortical bone results in failure by shearing or sliding along oblique surfaces. In reality, pure compression of a long bone (e.g., in a fall) results in crushing of the much weaker metaphyseal trabecular bone, such as with a tibial pilon or plateau fracture. **B:** Some fractures that combine bending and compression demonstrate transverse cracking as a result of bending followed by an oblique crack characteristic of compressive failure. The butterfly fracture with additional splitting of the fragment secondary to the initial fracture is an example.

the foot is not securely planted on the brake pedal and rotates with compression, is likely to result in a malleolar fracture,⁶³ although the combinations of forces causing these high-energy fractures are not entirely predictable.

A major mechanism of midshaft femur fractures is impact with the dashboard of the vehicle in a frontal collision, especially for unrestrained drivers who submarine or slide forward in the seat.¹⁶³ Tensing the quadriceps and hamstrings muscles during a crash applies significant additional compression along

the femur.¹⁶³ The anterior bow of the femur causes the external compressive force from contact of the knee with the dashboard, and internal muscle forces bend the femur, resulting in bending and transverse or oblique fractures. If the femur of the occupant hits the dashboard in an adducted orientation, the femur can be displaced from the acetabulum, causing a fracture of the posterior wall of the acetabulum and dislocation of the hip joint. Pelvic fractures can result from loading in side-impact crashes, in which the door punches inward against the hip and pelvis. The actual

fracture pattern of the posterior pelvis (sacrum, sacroiliac joint, or both) is probably the result of the specific alignment of the pelvis with the applied loads at impact. Some pelvic fracture classifications are based on the presumed mechanism of injury and specific forces applied.^{147,148,175,176} Bilateral hip fractures have been found to occur in crashes in which the vehicle has a large center console that tends to trap the pelvis as force is also applied on the hip opposite that which contacts the door. Upper extremity injuries in auto crashes have been found to be related to airbag deployment and entrapment of the arm in the steering wheel.⁷⁰

BIOMECHANICS OF FRACTURE IMPLANTS
Avoiding Mechanical Problems with Fracture Fixation Devices

When fracture implants fail prior to fracture union, a variety of underlying problems may be present, but in general, they can be divided into one of two categories: biologic or mechanical. Biologic causes of delayed union and fixation failure may be related to the patient’s systemic biology, such as smoking, chronic diseases such as diabetes, medications such as steroids, and many other causes. Although some biologic etiologies of fixation failure are only minimally under the surgeon’s control, others can be directly affected by the physician. The surgeon should make every effort to preserve soft tissue, respect the zone of injury, and preserve vascularity. Meticulous surgical technique, wound closure, and appropriate perioperative antibiotic therapy can all reduce the risk of infection and decrease the risk of treatment failure. When failure occurs acutely or prior to the expected time that fracture healing would occur, a mechanical issue is usually the primary culprit. Understanding the mechanical principles underlying stable fixation and fixation failure can help the surgeon determine the appropriate investigation and intervention.⁶⁷

Screw Breakage by Shearing During Insertion

A screw is a mechanical device that is used to convert rotary load (torque) into compression between a plate and a bone or between bone fragments. The basic components of a screw are shown in Figure 1-24. As shown in Figure 1-25, the thread of a screw, if unwound from the shaft, is really a ramp or inclined plane that pulls the underlying bone toward the fixation plate, causing compression between them.¹²⁹ To achieve this effect, the screw head and shaft should be free to turn in the plate; otherwise, the compressive force generated may be limited (Fig. 1-26). Locking screws thread into the plate holes, and although this fixed interface can be beneficial in certain clinical circumstances, it precludes compression between the plate and the bone.

Tapping is necessary in cortical bone so that the torque applied by the surgeon is converted into compression instead of cutting threads and overcoming friction between the screw thread and the bone (F_t in Figure 1-25) that it is being driven into (Fig. 1-27).⁸⁰ In some cases such as screw insertion into dense bone or the insertion of smaller diameter screws, the use of a separate tap followed by screw insertion can facilitate screw advancement into the bone. Most modern screw designs have self-tapping screw tips that cut the path for the threads as the

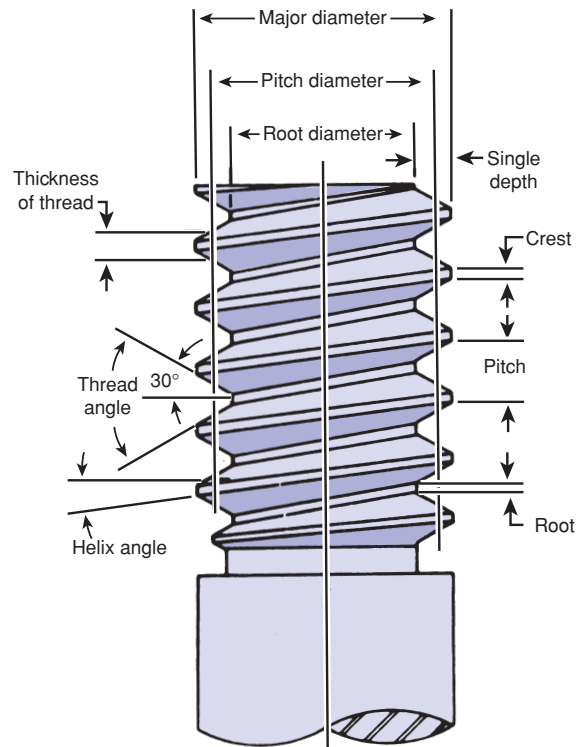

FIGURE 1-24 Nomenclature of screws. The root diameter is the inner diameter of the screw and the pitch defines the distance between threads.

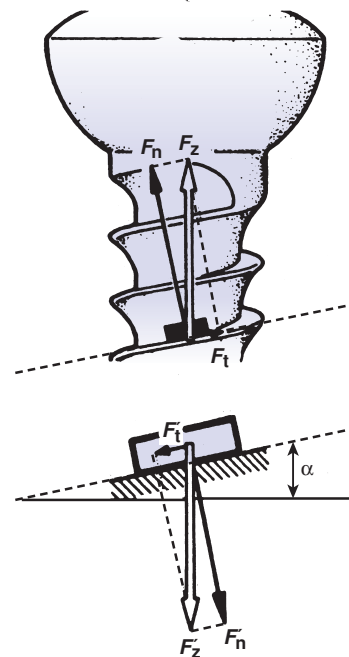

FIGURE 1-25 A screw is a mechanical device that converts torque into compression between objects. The screw thread is actually an inclined plane that slowly pulls the objects it is embedded into together. (F_n , normal or compressive force acting against the screw head; F_t , tangential or frictional force acting along the screw thread; F_z , resultant of the two forces; α , angle of the screw thread. The smaller the angle α [finer thread] the lower the frictional force.)

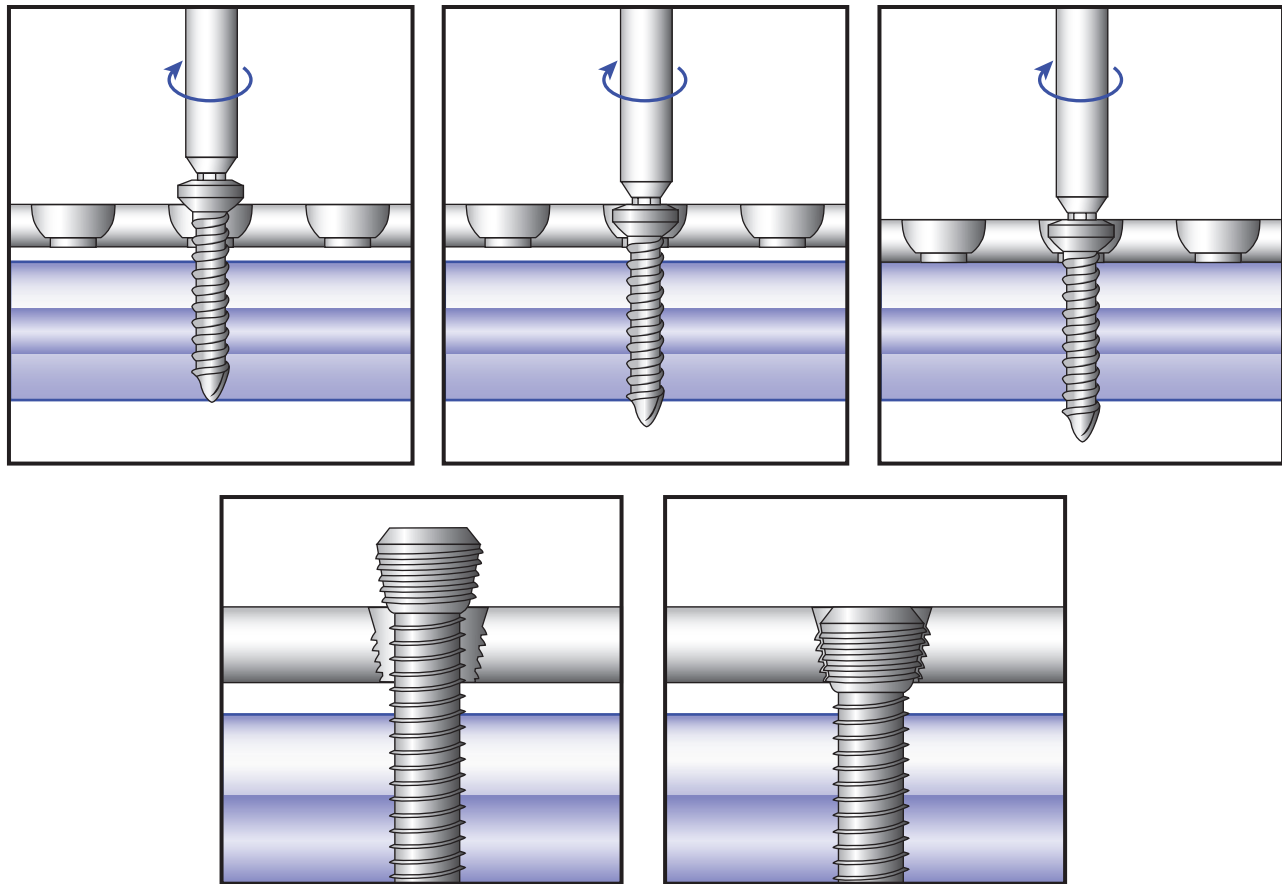

FIGURE 1-26 A comparison of cortical and locking screws. **Top:** Compression screw. As the screw is inserted, the head of the screw is free to rotate within the plate hole and thus allows for compression of the plate to the bone as the screw threads continue to drive the screw deeper into the bone. **Bottom:** Locking screw. As the screw is driven into the bone, the threads in the head of the screw engage and become fully threaded into the plate. Thus the screw is unable to apply a compression force to pull the plate and bone together.

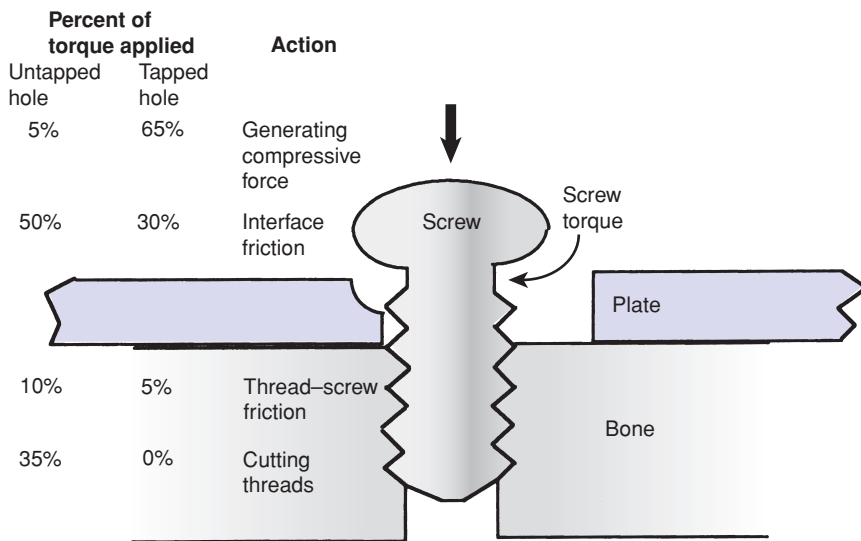

FIGURE 1-27 Schematic diagram showing the approximate distribution of torque acting on a screw placed into cortical bone. With a pre-tapped hole, about 65% of the applied torque goes to produce compression and 35% to overcome the friction associated with driving the screw. When the hole is not tapped, only about 5% of the torque is used to produce compression, the rest going to overcome friction and to cut threads in bone. These observations do not apply in cancellous bone.

screw is inserted. Screws with multiple cutting flutes at the tip of the screw appeared to be the easiest to insert and had greater holding power.¹⁷⁴ Tapping is less advantageous in cancellous bone as it may decrease the pull-out strength of the screw in cancellous bone.¹⁵⁷ In some cases, tapping the cancellous bone may be beneficial. A clinical example would be when treating femoral neck fractures in a physiologically older patient versus a younger patient; one may need to use a tap to create the threads in the denser bone of a younger patient. The reason to use the tap in the dense bone is to prevent the frictional forces causing rotation of the femoral head during screw insertion with resulting malreduction. In particularly hard bones the frictional forces become so great that it becomes difficult to advance the screw.

One problem during screw placement is shear failure of the screw, typically the head twisting off, leaving the shaft embedded in bone and difficult to remove. This can occur especially when not using a tap before insertion, or when inserting smaller (less than 4-mm diameter) screws in dense bone. The stiffness and strength of a screw are related to the fourth power of its radius (the effect of moment of inertia for screws of the same material). A 6-mm diameter screw is approximately five times as stiff as a 3-mm diameter screw and 16 times as resistant to shear failure by overtightening the screw during insertion. The junction of the screw head and threaded portion of the screw is a transition point in shape and size. Therefore, it acts as a stress concentrator and is usually the location of the screw breakage.

Screw Pullout

Particularly in cancellous bone, the maximum force that a screw can withstand along its axis, the pullout force, depends upon the size of the screw and the density of the bone it is placed into. As shown in Figure 1-28, when the force acting on the screw exceeds its pullout strength, the screw will pull or “strip” out of the hole, carrying the sheared bone within its threads, greatly decreasing the holding power and fixation strength. The pullout force increases with larger screw diameter, a greater number of

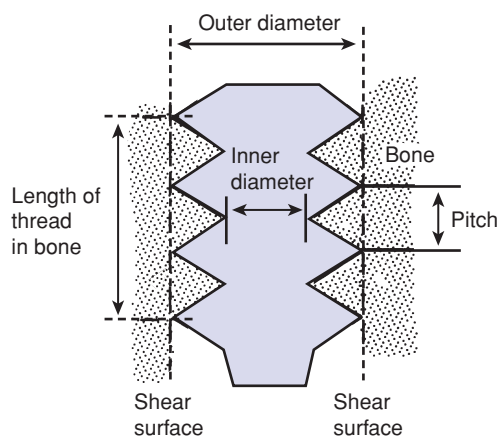

FIGURE 1-28 The factors that determine the pullout strength of a screw are its outer diameter and length of engagement (this defines the dimensions of a cylinder of bone that is carried in the threads and is sheared out as the screw is pulled out of bone) and the shear strength of bone at the screw–bone interface, which is directly related to its density. A finer pitch screw produces a small gain in purchase.³⁵

threads per unit length, a longer embedded length of screw shaft, and a greater density of the bone it is placed into.^{35,47,59,142} The diameter and length of the embedded screw can be thought of as defining the outer surface of a cylinder along which the screw shears. Given a maximum stress that bone of a particular density can withstand, increasing the surface area of the screw cylinder increases the pullout force (because force = stress multiplied by the area over which it acts). To enhance screw purchase, consider embedding the largest-diameter screw possible into the bone of the greatest density over as long a purchase length as possible.^{35,47} Clinically, however, there are downsides to placing the largest-diameter screw possible. Larger screws can occupy a large volume in small fracture fragments, limit the number of fixation sites possible, and propagate adjacent fracture lines.

In cancellous bone, screw pullout becomes a more significant problem because the porosity of cancellous bone reduces its density and therefore its shear strength.¹⁵⁷ Hole preparation, specifically drilling, but not tapping, improves the pullout strength of screws placed into cancellous bone (such as pedicle screws in the vertebral body).³⁵ The reason that tapping reduces strength in cancellous bone, as shown in Figure 1-29,

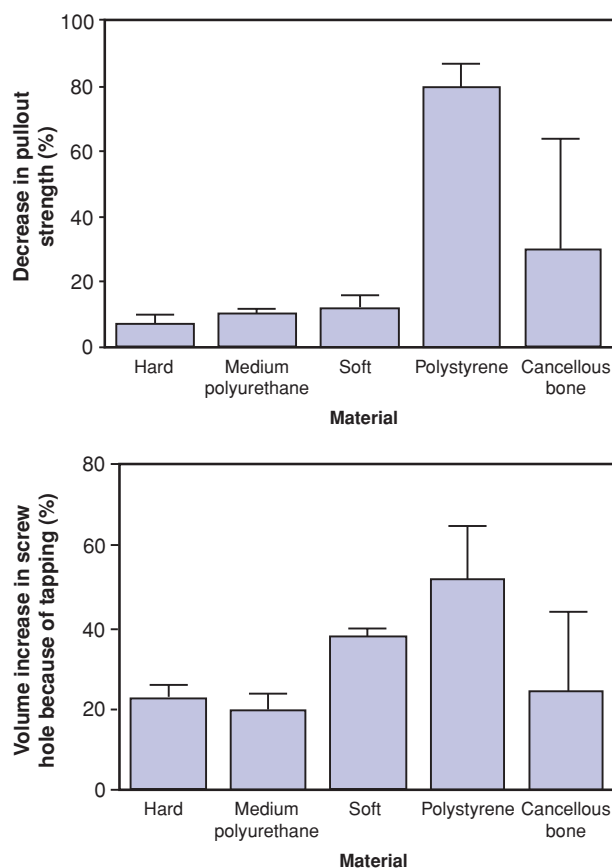

FIGURE 1-29 **Top:** The decrease in pullout strength in various types of foam used to test bone screws demonstrating the percentage decrease in pullout strength between screws placed into holes that were either drilled only or drilled and tapped. **Bottom:** The percentage increase in volume comparing holes that were drilled only and those that were drilled and tapped. Tapping in cancellous bone increases hole volume, which decreases pullout strength.³⁵

is that running the tap in and out of the hole removes the bone, effectively increasing the diameter of the hole and reducing the amount of bone material that interacts with the screw threads. Tapping has a more detrimental effect as bone density decreases and can reduce the pullout strength from 8% to 27%.³⁵ Pullout strength can also be related to the time after insertion. As the bone heals, it can remodel around the screw, potentially doubling its initial pullout strength.¹⁴²

Recent research has focused on whether pullout strength is an appropriate measure of screw performance in cancellous bone.¹³¹ In a nonlocking plate and screw construct, much of the stability of the construct is from the friction generated from compression between the plate and the bone. As a screw is inserted into the bone, if it is able to generate high values of insertional torque, this will result in increased compression of the plate to the bone and increased stability. As the maximum insertional torque is reached and then exceeded, the screw will then “strip out” and lose its purchase in the bone. Although a relationship exists between maximum insertional torque, screw pitch, and compression forces, in this study, pullout strength was found to have no correlation with either the maximum insertional torque or screw pitch. Thus, this may be a better way to measure screw performance and optimize screw characteristics.

Screw Breakage by Cyclic Loading

Once screws are successfully inserted and the construct is finalized, screws become subject to cyclic bending forces as the patient begins to mobilize (Fig. 1-30). Ideally, a nonlocking screw is initially tightened against the plate to achieve the maximal torque possible, which is converted to the maximal

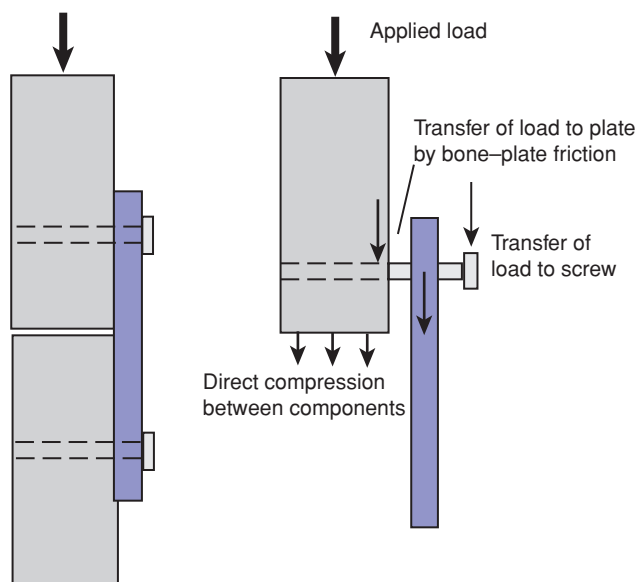

FIGURE 1-30 A mechanism for rapid failure of screws in cyclic bending occurs when the screw has not been tightened sufficiently to keep the plate from sliding along the bone surface (the plate–bone gap shown here is exaggerated for clarity). The result is that bending loads are applied transverse to the long axis of the screw, which in combination with fretting corrosion caused by the screws rubbing against the plate results in early failure of the screw.

compressive force between the plate and the bone (Fig. 1-27). The screw holds the plate against the bone partly by frictional contact, which depends on the frictional force generated between the undersurface of the plate and the bone. The frictional force is directly dependent on the compressive force generated by the screws. If any sliding occurs between the plate and the bone, the bending load will be transferred from the head of the screw into the plate, where screw–plate contact occurs. Bending loads perpendicular to the axis of the screw, along with possible stress corrosion and fretting corrosion, may cause the screws to fail rapidly in fatigue. Zand et al.¹⁷⁷ showed that screws tightened against a plate with 10% to 15% less than the maximum force failed in less than 1,000 loading cycles by bending fatigue, compared with fully tightened screws that were able to sustain over 2.5 million loading cycles. This emphasizes the clinical importance of ensuring screw tightness during plate fixation.

Screws that lock into the plate reduce this problem as it is less subjective when threaded screw heads are fully tightened into the plate hole. Small-fragment screws (3.5- to 4-mm outer diameter) can fatigue because their core diameters are small. The trade-off in the use of locking screws is that a screw with a larger core diameter and shallower thread reduces the possibility of fatigue failure, but a smaller core diameter and deeper thread can increase purchase strength in the bone.¹¹⁷ Screws with smaller core diameters fatigue and fail more rapidly than screws with larger diameters. The fatigue strength of the screw must be weighed against the purchase power of the screw as well as the size of the screw in relation to the size of the bone fragment. In some cases the decision must be made between a screw with a large core diameter with shallower thread, which maximizes fatigue strength or a smaller core diameter screw with deeper threads, which maximizes purchase power.

Cannulated screws are used for fixation when the insertion of a guide wire is helpful to guide the future path of the screw. However, drilling precision for the guide wire is decreased with increasing density of bone and the use of longer- and smaller-diameter guide wires.⁷⁹ Cannulated screws follow the same mechanical principles as solid screws, but material must be removed from the center of the screw to accommodate the channel for the guide wire. Manufacturers commonly increase the core diameter (the diameter of the screw at the base of the thread) to accommodate for the loss of this central material. The same-size cannulated screws usually have less thread depth compared with solid screws. The result—depending on the screw size—is less pullout strength. For 4-mm diameter screws, cannulated screws of the same outside diameter had about 16% less pullout strength.¹⁶⁰ Alternatively, to keep the same thread depth, the outer diameter of the screw may be increased. An additional consideration is that cannulated screws are significantly more expensive than solid screws.

Fully Threaded Lag Screws

The lag screw is a very effective device for generating large compressive forces across fracture fragments and the fracture site. The head and upper part of the shaft of the screw must be allowed to glide in the near fracture fragment so that it pulls the far fracture fragment toward it to create compression across

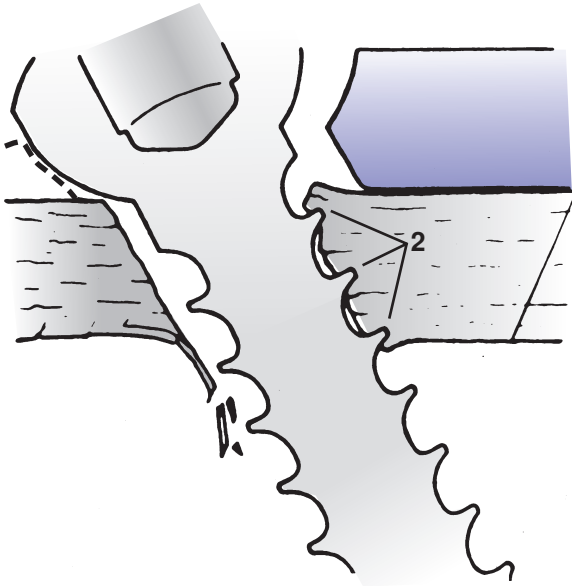

FIGURE 1-31 Using a fully threaded lag screw causes the threads to engage in bone on both sides of the fracture. This inhibits the screw from compressing the bone fragments together.⁹¹

the fracture surface. As shown in Figure 1-31, a fully threaded lag screw can block the gliding action between the two fracture fragments. Comparing the compressive forces across the fracture site using fully and partly threaded lag screws demonstrated that the average compressive force at the opposite cortex (i.e., the force in the screw itself) was about 50% greater when a partly threaded screw was used.⁹¹

Breakage of Fracture Fixation Plates

Fracture fixation plates can be used for several different functions, depending on how they are applied. One common application is for use as a “compression plate” in an attempt to achieve rigid stability. In this mode, the fracture fragments are driven together, compressing them. This is beneficial to fracture healing because it improves stability, allows primary

bone healing with minimal callus formation, and enhances the resistance of the plate to bending fatigue failure. Observing the cross section of an oval hole in a dynamic compression fracture plate, Figure 1-32 shows that one border of the hole actually has a cup-shaped inclined surface. When the head of the screw advances downward toward the bone surface, the screw and the fragment of bone it is attached to slide toward the center of the plate. This action, which occurs in both fracture components, causes the fracture surfaces to be driven together⁴ and creates significant compressive forces across the ends of the fracture.³⁹ Compressing the ends of the fracture significantly improves the stability of the construct and reduces bending and torsional stresses applied to the plate, increasing its durability. Stability is improved because the bone ends resist bending forces that close the fracture gap, and torsional loads are resisted by the frictional force and interlock between the ends of the fracture components. Also, the fracture gap that must be healed is smaller.

It is important to appreciate that the plate is vulnerable to bending failure, because plates are relatively thin and easy to bend (compared with bone), and have low moments of inertia. When used to apply compressive force to the ends of the fracture, the stabilized bone can then resist the bending loads applied during functional use. If a gap is left on the side opposite the plate (Fig. 1-33), as when a bridge plating technique is used, the fracture site can become a fulcrum around which the plate bends under combined compressive and bending loads such as those which occur with axial loads. Gapping can also occur when a segment of bone is missing at the fracture site, or if the plate is not properly contoured during application. Figure 1-34 demonstrates how a flat, noncontoured plate tightened against a flat bone surface will cause a gap to appear on the opposite cortex.¹²⁴ This is why a plate should be slightly overcontoured to create an initial gap between it and the bone surface it will be applied to.^{73,125,143} Gapping at the fracture also occurs when the plate is applied to the predominantly compressive side instead of the tensile side of a long bone during functional loading that causes bending. Figure 1-35 demonstrates that placing the plate on the compressive side will cause a gap to open under load.

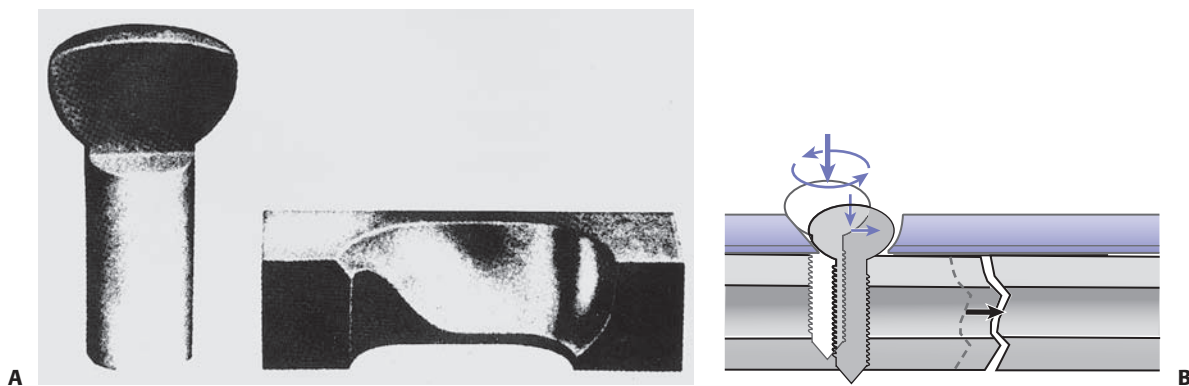

FIGURE 1-32 A: Cross section through the head of a bone screw and the hole in a fracture plate showing the geometry. **B:** As the screw is tightened, the head slides down the inclined border of the plate, which displaces the screw sideways, and therefore, the screw and the bone fragment to which the screw is attached are displaced toward the opposite fragment.

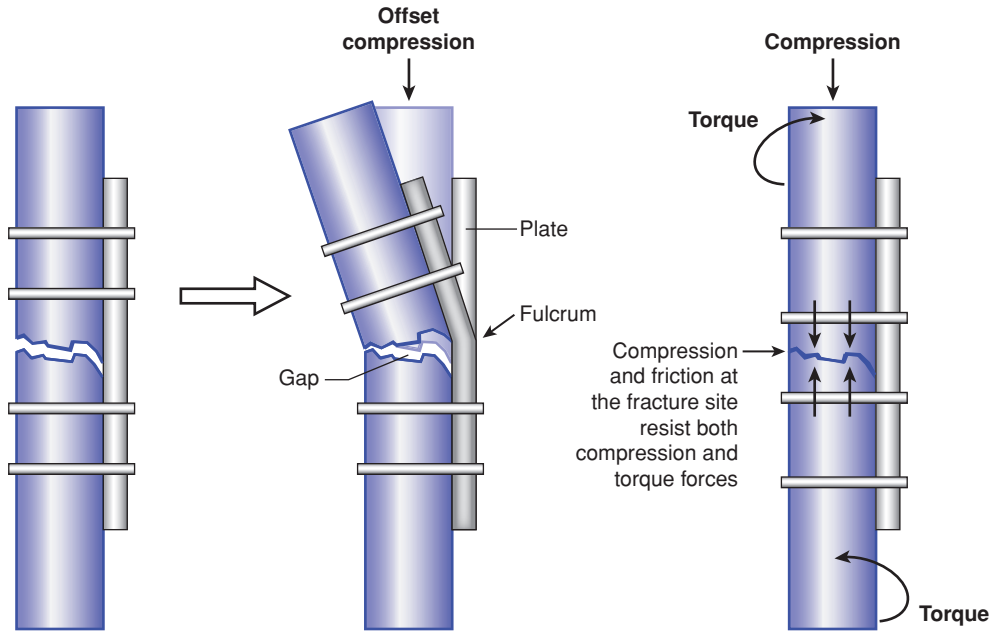

FIGURE 1-33 **Left:** When a gap is left on the cortex opposite that to which the plate is attached, bending of the plate at the fracture site can cause the plate to fail rapidly in bending. **Right:** Compressing the fracture surfaces not only allows the bone cortices to resist bending loads but the frictional contact and interdigitation help resist torsion.

Plate stresses are significantly increased by gapping at the fracture.¹⁴ In comminuted fractures in which it is difficult to approximate the fracture ends, bridge plating can be performed, and screws should be placed as close as possible across the fracture gap and spread over a long plate length to reduce strains in the plate.⁵⁵ Torsional and bending stiffness of a fracture construct can be significantly increased, and therefore, plate strain reduced, by increasing the length of the plate itself.¹⁴¹ While

increasing the number of cortices of fixation also increases the stiffness, as shown in Figure 1-36, the number of screws is not the sole determinant of construct stiffness.⁵⁶ Figure 1-37 shows several interesting aspects related to plate fixation with screws. First, plate strains are highest at the two holes adjacent to the fracture gap and become very small five holes away from the fracture (locations 2, 3, 4, and 5), far from the fracture

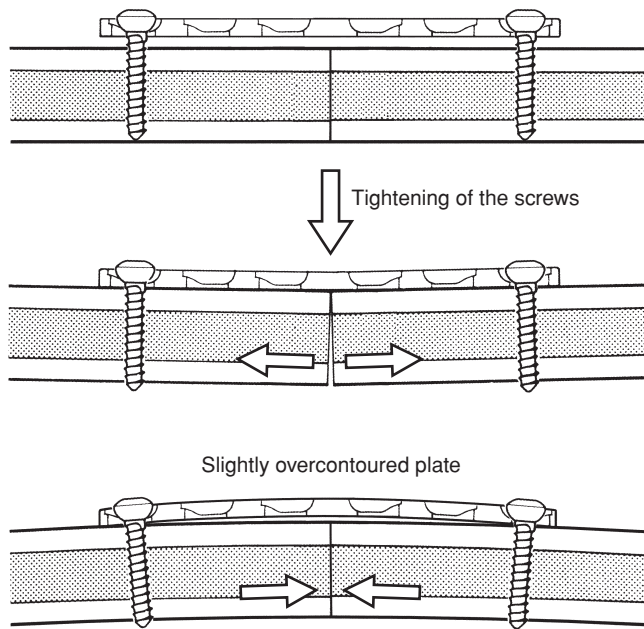

FIGURE 1-34 A demonstration of the gapping that occurs on the opposite cortex when a flat plate is applied to a flat bone surface. Slightly prebending the plate causes the ends of the opposite cortices to be driven together when the plate is applied.¹²⁴

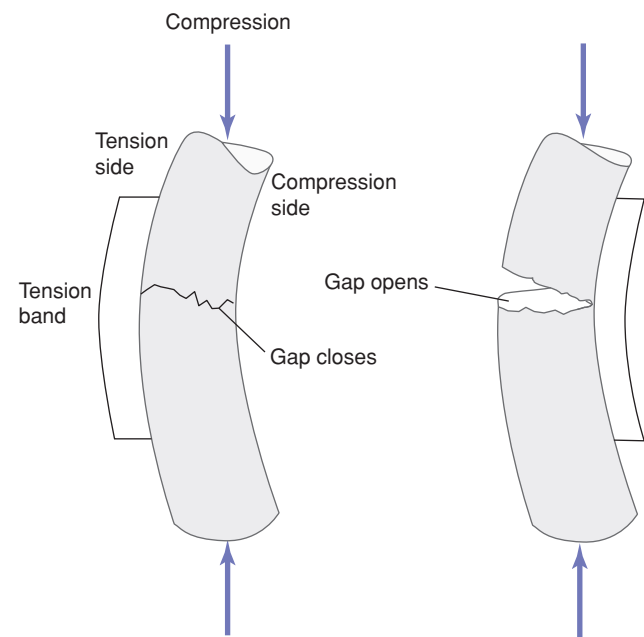

FIGURE 1-35 The application of a plate on the compressive as opposed to the tensile side of a bone subjected to bending causes a gap to open on the opposite side of the plate during functional loading.

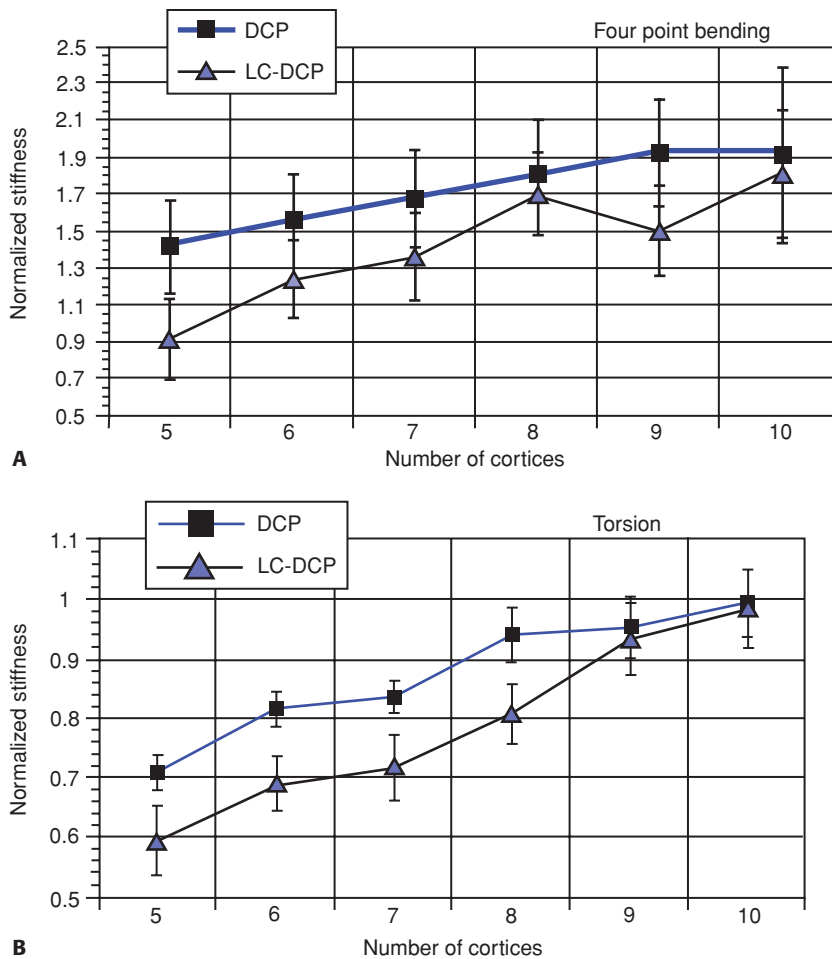

FIGURE 1-36 Relative stiffness of a plate–bone construct in (A) torsion and (B) bending as a function of the number of cortices through which screws have been placed (DCP, dynamic compression plate; LC-DCP, limited contact dynamic compression plate).⁵⁴

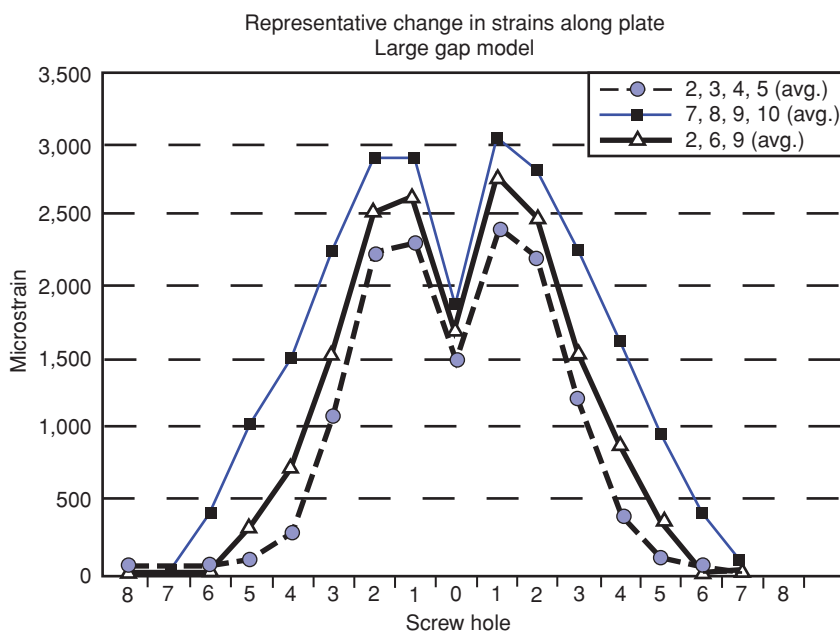

FIGURE 1-37 Distribution of strain (measured in microstrain or strain $\times 10^{-6}$) at various locations along a plate regardless of placement of the screws in different locations (holes 2, 3, 4, 5), (holes 7, 8, 9, 10), or holes (2, 6, 9).⁵⁶

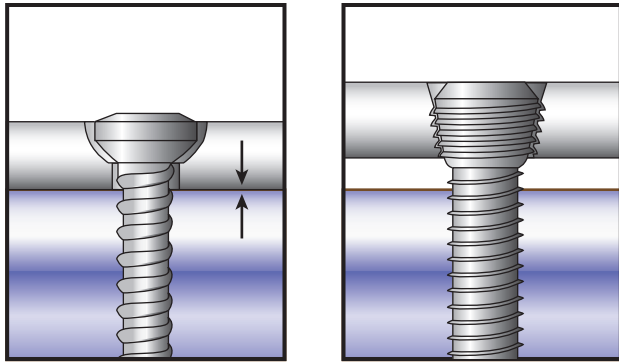

FIGURE 1-38 The difference between the conventional screw and locking screws are shown. The conventional screw has a smooth screw head that allows for compression between the plate and bone. The locking screw has a threaded screw head that engages the plate and “locks.” It does not allow for compression between the plate and bone. The locking screw also has a finer screw pitch and a larger core diameter to increase resistance against bending forces.

(locations 7, 8, 9, and 10), or mixed (locations 2, 6, and 9).⁵⁵ This data also indicate that not all holes of the plate need to be filled with screws to provide similar fixation stiffness.

Locking Screws and Plates

Locking screws and plates are newer types of implants that can be used in the treatment of fractures. Most locking screws have threads machined into the screw heads, which can thread into the plate, thus locking with the plate and creating a fixed angle device (Fig. 1-38). In addition, the screws have been designed with a finer thread and larger core diameter, as torque generation during insertion is less of a priority, and resistance to bending forces is paramount.⁵⁵ As stated above, the bending stiffness of the screw is related to the radius to the fourth power. Locking plates function differently biomechanically compared with nonlocking plates. Nonlocking plates are compressed against the bone fragments by the screws and require bone-to-plate contact to produce a stable fracture construct. When the frictional forces of the bone–plate interface are greater than the load applied, a stable construct results. When the frictional force generated is less than the load applied, the construct becomes unstable (Fig. 1-39).

Locking plates and screws are rigidly connected to the plate which creates a fixed angle device that acts like an external fixator (Figs. 1-40 and 1-41).⁶² Because each screw acts as a fixed implant they do not rely on bone quality as much as conventional screws. Conventional screws need good bony purchase to create the compression needed to secure the construct, whereas locking screws act as fixed angle devices that rely on the plate–screw interface, shear strength of the screw, and the compression strength of the bone for stability of the construct (Fig. 1-42).

Conventional screw constructs fail differently when compared with locking screw constructs (Fig. 1-43). When conventional constructs fail, it is usually because of loss of bony purchase of the screw and sequential pull out of the screws. Because the locking screw creates multiple fixed angle devices,

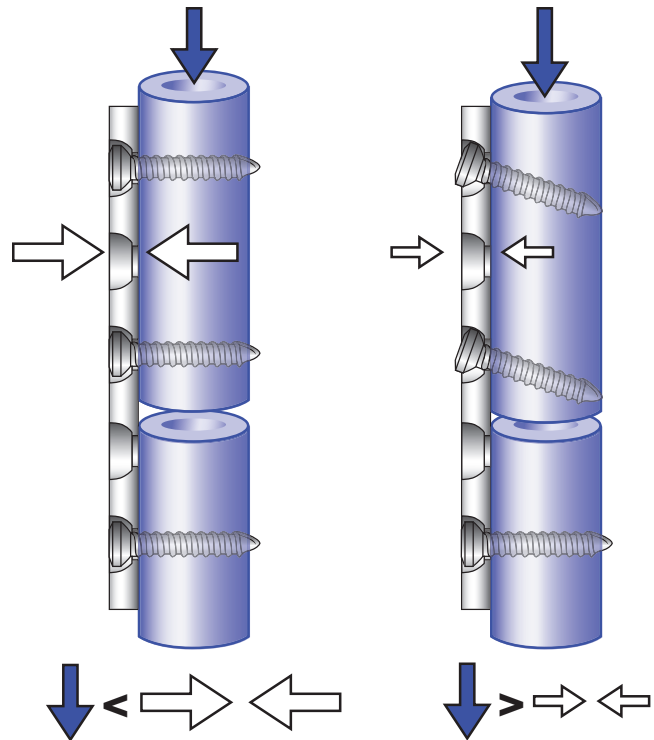

FIGURE 1-39 The function of a conventional plate and screw construct relies on frictional forces between the plate and bone to resist the applied force. When the frictional forces are greater than the load applied, the construct is stable. If the load applied is greater than the frictional forces the construct can fail.

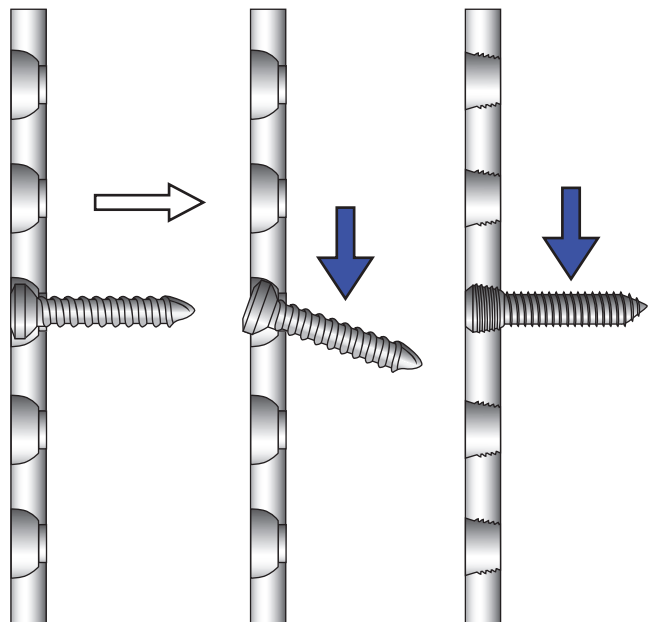

FIGURE 1-40 Because the conventional screw does not engage the plate when load is applied the screw has no angular stability. Thus it relies on the frictional forces between the plate and bone for stability. The locking screw engages into the plate and is able to resist the load because of the screwhead threading into the plate; thus, it is a fixed angle device.

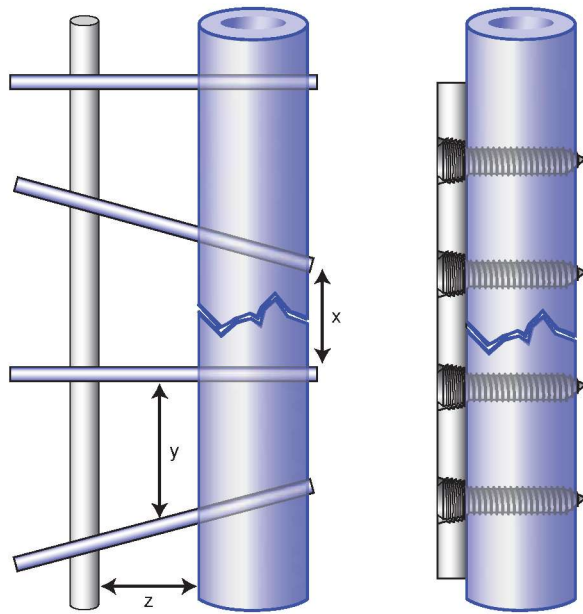

FIGURE 1-41 Locking plate–screw construct functions as an internal fixator. Decreasing the value of x , y and z (X - pin to fracture distance, y - pin to pin distance, z - bar to bone distance) will increase the stiffness in a fixed angle construct. A locking plate helps to do that by reducing z . The values of x and y can be modulated by the surgeon and how the pins or screws are placed.

the screws must all fail simultaneously and the entire construct ultimately fails only after compressive failure of the bone. As stated previously the bone is weakest in tension and strongest in compression.

The locking construct does not rely on compression between the plate and bone; therefore, the plate does not have

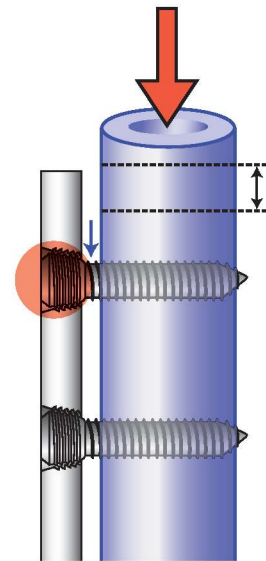
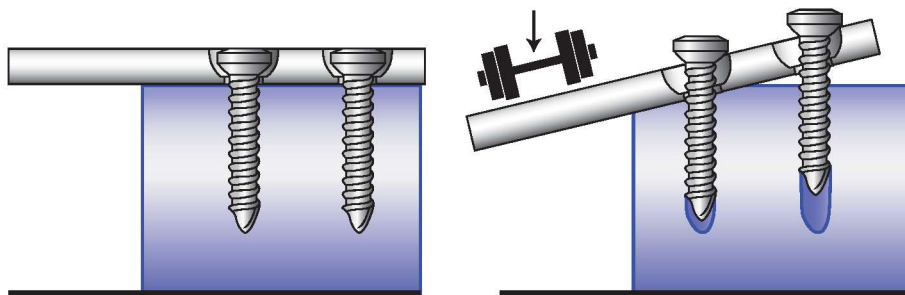

FIGURE 1-42 When load is applied (red arrow) to a locking construct, the load is resisted by the plate–screw interface (orange circle) acting as a fixed angle device. Also the screw shaft (arrow) exposed between the plate and bone resists the shear forces. And because of the fixed angle construct, the forces applied are also resisted by compression of the bone (orange rectangle).

to sit directly on the bone. This can preserve the soft tissue envelope and periosteum, and cause less interference with the biologic processes of fracture healing. Also, locking plates provide more stability in comminuted fractures¹⁵¹ in which cortical apposition and compression are difficult to achieve and fracture mechanical stability occurs mainly from the implant.⁵²

Conventional screw construct



Locking construct

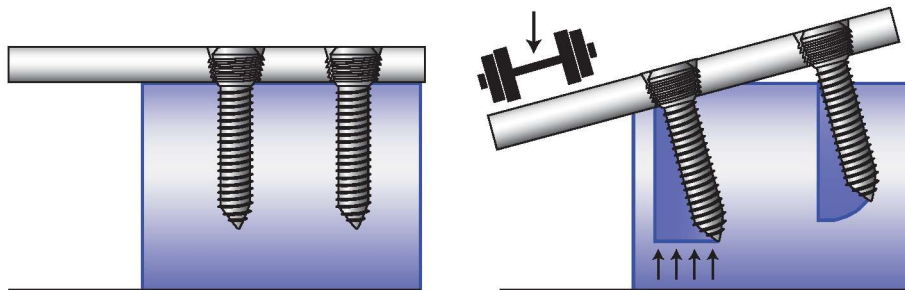

FIGURE 1-43 The conventional screw construct fails when the screws lose purchase in the bone and pull out of the bone. Note the screws fail sequentially. The locking construct acts as a fixed angle device and failure results when the bone fails in compression and all the screws fail simultaneously.

However, locking screws cannot create compression at the fracture site and thus rely on relative stability.

Dynamic fatigue testing has shown that locking plates have fatigue strengths similar to other systems and are able to support loads comparable to one body weight for two million cycles, which should be sufficient for normal fracture healing. Since screw pullout strength is related directly to the length of screw purchase in bone cortex, unicortical screws used in some systems have lower pullout strength than bicortical screws and should be avoided. As with other systems, locking plates have mechanical sensitivities. For example, accurate placement of the locking screws is important. As Figure 1-44 shows, angulation of the screw causes incomplete engagement of the thread at the screw–plate interface and, therefore, lower mechanical stability of the construct. In fact, comparatively, the bending stability of a 4.5-mm locking plate was reduced to 63% and 31%, respectively, with 5- or 10-degree axis deviation of the locking screw insertion vector.⁸⁶ Although some of the newer systems do allow for variable angle locking trajectories, deviating from the design parameters will result in loss of mechanical stability of the screw–plate interface.

Plate Failure Through a Screw Hole

Many plates have multiple screw holes to provide many fixation options depending on the specific requirements of the fracture pattern and bone quality. It is not necessary to place screws in every hole in the plate,⁴⁸ but the effects of screw placement on fixation stiffness should be understood. An empty screw hole

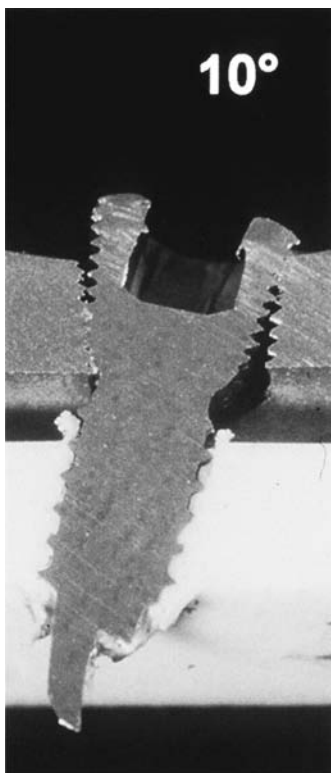

FIGURE 1-44 A demonstration of the importance of accurate placement of locking screws into the plate.⁸⁶

is an area of elevated stress on the plate, unless the plate is made thicker near the holes to compensate, as is the case with some implants. The plate material around the holes will have higher material stresses than occur in the solid regions of the plate. Around the holes, the force acts through a smaller cross-sectional area, so the material stresses must be higher. A second consideration related to multihole plates is that separating the screws, so that there is a greater distance between them across the fracture site, that is, increasing the “working length” of the construct, results in lower stiffness of the plate–fracture construct.⁶⁷ With an increased working length, a given applied load is distributed over a longer segment of plate, decreasing the amount of stress per unit length of the plate. This may have beneficial biologic ramifications as well, as fracture site motion is distributed to more of the comminuted fragments, decreasing strain at each fragment, and increasing the likelihood of callus formation.

Femoral Splitting as a Result of Intramedullary Nail Insertion

Insertion of an IM nail into the femur can lead to difficulties because the femur has a significant anterior curvature,¹⁷⁸ shown in Figure 1-45. Current femoral nails have radii of curvature that range from 186 to 300 cm, compared with an average of 120 ± 36 cm for a large sample of human femora. Therefore, current femoral nails are considerably straighter than the average human femur, especially in older individuals where anterior femoral bowing may be increased.⁵¹ The nail, which has a curved shape to accommodate the femoral bow, must also conform to the curvature of the femur as insertion progresses. Placing a nail, which is essentially a curved spring, down the femoral canal causes the nail to bend slightly, because the femur is generally much stiffer than the nail (Fig. 1-46). In fact, the nail must conform not only to an anterior–posterior bow but also canal curvature medially and laterally.⁵³ Figure 1-47 demonstrates that nail contact with the internal surfaces of the femur generates forces which resist insertion. These nail–femur contact forces or “hoop stresses” directed perpendicular to the



FIGURE 1-45 Cross sections of various femora demonstrate the curvature that an IM rod must conform to when it is fully inserted.¹⁷⁸

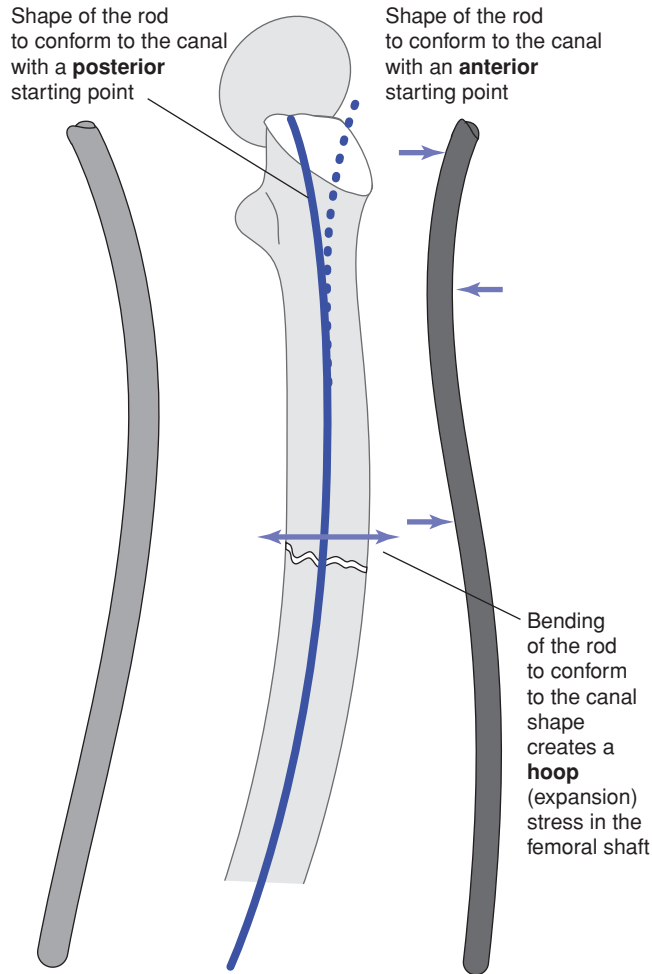

FIGURE 1-46 Mismatch of the curvature between the IM rod and the medullary canal results in bending stresses that could cause splitting of the femur during insertion.⁸⁵

surface of the medullary canal cause the femur to expand and will result in splitting or fissuring if they become too large.⁸⁵

The factors that govern the amount of bending of the nail during insertion and the resulting internal forces acting within the femur are the proximal start position, the length of the proximal fragment, the initial curvature of the IM nail compared with the curvature of the femur, and the bending stiffness of the nail. Nail stiffness can vary considerably, and depends heavily on diameter and material.¹³⁹ Many currently used nails are titanium, which is a less stiffer metal than stainless steel. Figure 1-47 demonstrates examples in which malposition of the proximal start point resulted in femoral splitting during nail insertion.⁸⁵ Some newer IM nails employ a valgus bend to be used with a femoral trochanteric entry portal.¹²⁶ The optimal entry point for retrograde nailing was found to be about 1.2 cm anterior to the femoral origin of the posterior cruciate ligament and at the midpoint of the intracondylar sulcus.⁹⁶

IM Nail and Locking Screw Breakage

Fractures of IM nails and locking screws occur occasionally during healing. The most demanding mechanical situation for

IM nail fixation of the femur or tibia occurs when the fracture is very distal. Figure 1-48 compares the forces acting on idealized femora with more proximal and more distal fractures. For a specific location of the external load (muscle load or body weight), the more distal fracture results in a longer moment arm (the perpendicular distance from the load to the fracture site), creating a greater moment, and therefore higher stresses in the implant. The highest stresses in the nail occur near the fracture site. With a distal fracture, in addition to the greater moment, the locking holes—which are significant stress risers—are usually located just distal to the fracture site. It has been shown that the maximum stresses acting in the nail increase rapidly once the distance between the fracture and the most superior of the distal screw holes is reduced to less than about 4 cm.³⁰ Cyclic loading of nails used to fix distal fractures, with peak loading of about one body weight, confirm that titanium alloy nails can survive more than one million loading cycles when the more proximal of the distal locking screws is more than 3 cm from the fracture site.⁷ In addition, placing the distal locking screws can be difficult because they must be inserted freehand under fluoroscopic guidance. Sometimes, the corner of the screw hole of the nail can be nicked by the drill or while driving the screw, creating an additional stress riser that can accentuate the fatigue process. Awareness of these potential problems has led to design changes such as closing the proximal section of the nail, increasing material thickness around the screw holes, and cold forming, which increases the strength of the material.

Screw bending and breakage can also occur. When distal screws are placed into the bone with relatively low bone density, the screw is supported mostly by the cortices. The distal end of the femur widens rapidly (Fig. 1-49), so the unsupported length of the screw between the cortices can be quite variable. For the same diameter and material, the stiffness and strength of a screw subjected to bending decreases with the third power of its unsupported length (the distance between cortices, assuming no support from the trabecular bone). If the unsupported length of one screw is twice as long as that of another, and assuming that the trabecular bone does not contribute to support of the screw, one can expect the stiffness and strength of the screw with the longer unsupported length to be one-eighth that of the screw with the shorter length between cortical supports, and therefore, the deformation will be eight times greater under the same load. This does create a trade-off in fixation of these fractures with respect to screw placement. If the screws are too close to the fracture, the stresses in the nail increase, whereas if they are located within the flair of the metaphysis, with poor trabecular bone, their unsupported length increases, decreasing stiffness and strength. The fatigue life of the distal locking screws is directly related to the diameter of the root of the thread and the resulting moment of inertia, so it has been proposed to remove the threads to increase fatigue life by 10 to 100 times.⁷⁸ Stresses on interlocking screws are also significantly increased in comminuted fractures, where no load can be borne by the cortices at the fracture site, as is the case with simple transverse or short oblique fracture patterns.



FIGURE 1-47 The starting position selected for rod entry into the medullary canal affects the degree to which it must bend and the internal forces generated in the femur. A starting position offset from the axis of the medullary canal, coupled with a stiff rod and a longer proximal segment that requires the rod to bend more during insertion, generate higher insertion forces and internal femoral forces. In this example of a midshaft femoral fracture (**left**), the starting hole was selected medial relative to the axis of the medullary canal (**middle**) and posterior (**right**). The medullary canal is outlined in dashed lines. Therefore the rod must bend both medially and posteriorly as it is inserted into the canal and has created internal stresses which have split the distal end of the proximal femoral segment.⁸⁵

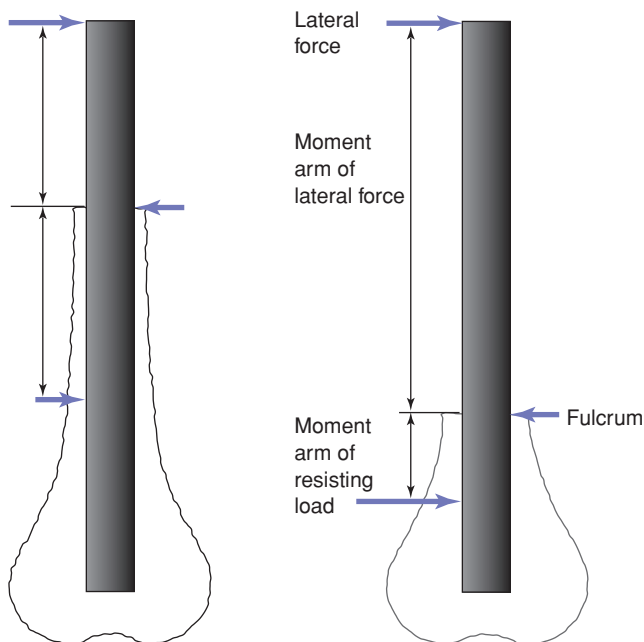

FIGURE 1-48 If the same force acts on IM rods placed in femora with more proximal (**left**) or more distal (**right**) fractures, the moment arm of the force will be longer in the case of the more distal fracture and therefore the moment acting at the fracture site on the implant will be larger. For the more distal fracture, the high-stress region close to the fracture site is also significantly closer to the distal locking screw holes which are significant stress risers.

Loosening of External Fixator Pins

Loosening of fixator pins in bone is thought to result from several causes. The shape of the end of the pin itself, because it is self-tapping, can affect the local heat generated in the bone

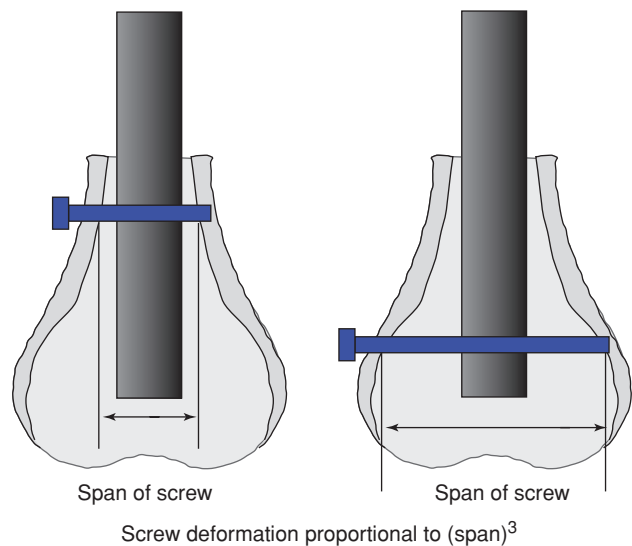

FIGURE 1-49 Because the distal end of the femur flares rapidly, the length of the locking screw required to crosslock the rod can be quite variable. If the screw is not well supported by trabecular bone but mainly by cortex, then its stiffness and strength decrease with the third power of its length between cortices. If the screw length doubles, the deformation of the screw under the same load increases by a factor of eight.

during insertion, potentially causing thermal necrosis around the pin hole site,¹⁶⁹ along with bone microfracturing. In addition, high local stresses can occur in the pins and bone if the hole through which the pin is inserted is undersized.⁸² A third mechanism, shown in Figure 1-50, is micromotion, which induces bone resorption at the pin–bone interface if the pin is a loose fit in the hole. To reduce these problems, slight undersizing of the bone hole by about 0.1 mm in diameter has been advocated. If the bone hole is undersized by 0.3 mm in diam-

eter, the yield strength of bone may be exceeded when the pin is inserted, resulting in fracture.¹²⁴

Excessively Flexible External Fixation

An external fixator is an assembly of pins attached to bone fragments, along with clamps and sidebars that couple the pins. This assembly allows considerable variation in construction of a frame to accommodate the fracture. The optimal stiffness of a fixator necessary to stabilize the fracture and induce healing changes as the fracture consolidates is not specifically known. It must be rigid enough to support the forces applied by the patient during ambulation without causing malalignment of the fracture. However, it should not be so stiff that the fracture is shielded from the motion required to stimulate healing by callus formation. Some basic mechanical guidelines in the construction of the frame, explained below, will ensure that frames are adequately constructed for the loads they are subjected to. Figure 1-51 demonstrates that when the diameter of a pin or sidebar increases, its stiffness and strength increase to the fourth power of the relative change in diameter (actually the ratio of the larger to the smaller diameter). As its length (the distance between bone surface and sidebar) decreases, stiffness and strength increase to the third power of the length change. This principle also holds for the pins spanning the fracture, which affect the unsupported length of the sidebar across the fracture.

In the construction of a frame, it is beneficial to decrease the sidebar-to-bone distance (which decreases the unsupported lengths of the pins), increase the pin diameter, and decrease the distance between the pins which span the fracture. Similarly, increasing the number of pins applied also increases frame stiffness. In terms of actual effects on bending strength, doubling the sidebar distance from bone decreases frame stiffness by approximately 67%, doubling the separation distance of the pins across the fracture decreases stiffness by 50%, and decreasing pin diameter by 1 mm (e.g., from 6 to 5 mm) decreases frame stiffness by about 50%.¹⁶¹ Using a partly threaded pin and burying the pin thread completely within the cortex enhances the stiffness of the pin because the smaller diameter of the root of the pin thread is not exposed. Also, using hydroxyapatite-coated external fixation pins to enhance the screw–bone interface¹²³ has been shown to improve fixation and pin longevity.

The comments above pertain to uniplanar fixators, which are constructed to resist the major loads of axial compression and anterior–posterior bending that act on a long bone such as the tibia during walking. To resist torsion and out-of-plane (medial–lateral) bending, the fixator can be assembled with additional pins and sidebars in other planes. A comparison of the relative stiffnesses of different fixator assemblies is given in Figure 1-52. The unilateral half-pin frame with sidebars mounted at right angles provides the greatest overall resistance to bending, compression, and torsional loads.²¹ Hybrid fixation devices have adopted components of both unilateral bar fixators and ring fixators with transfixing small-diameter wires. Both axial compression and torsional stiffnesses have been found to increase significantly with increases in the number and diameter of the transfixing wires, and pretensioning the wires.³³ More anterior placement of wires, or addition of an anteromedial half

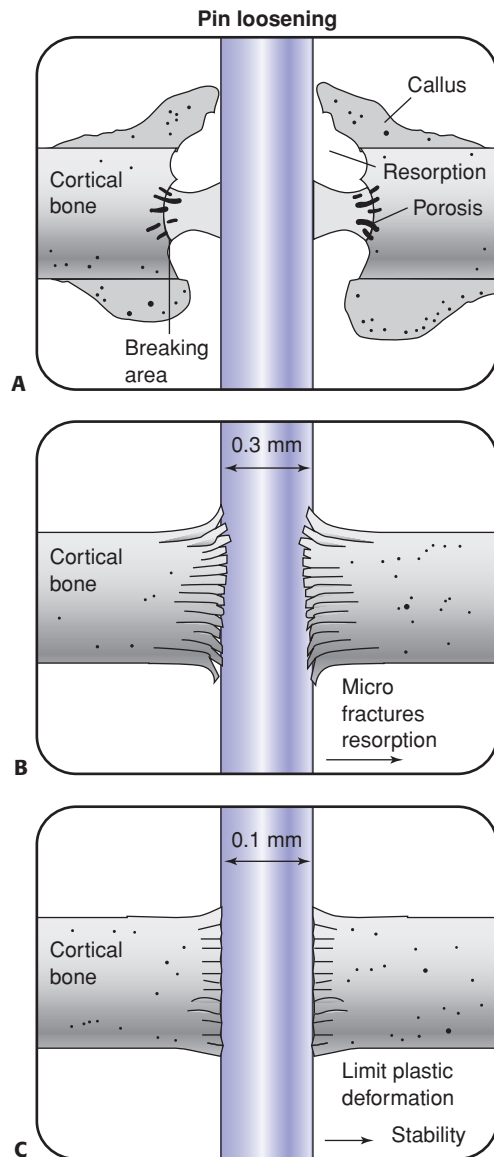

FIGURE 1-50 A proposed mechanism for loosening of external fixation pins involves under- or oversizing the diameter of the pin relative to the bone hole. **A:** If the pin and bone hole are of the same diameter, micromotion can occur with bone resorption. **B:** If the pin is more than 0.3 mm smaller in diameter than the hole in the bone, microfracture may occur during insertion. **C:** If the bone hole diameter is about 0.1 mm smaller than the pin diameter, the bone is prestressed but does not fracture, micromotion is eliminated, and pin stability is maintained.¹²⁴

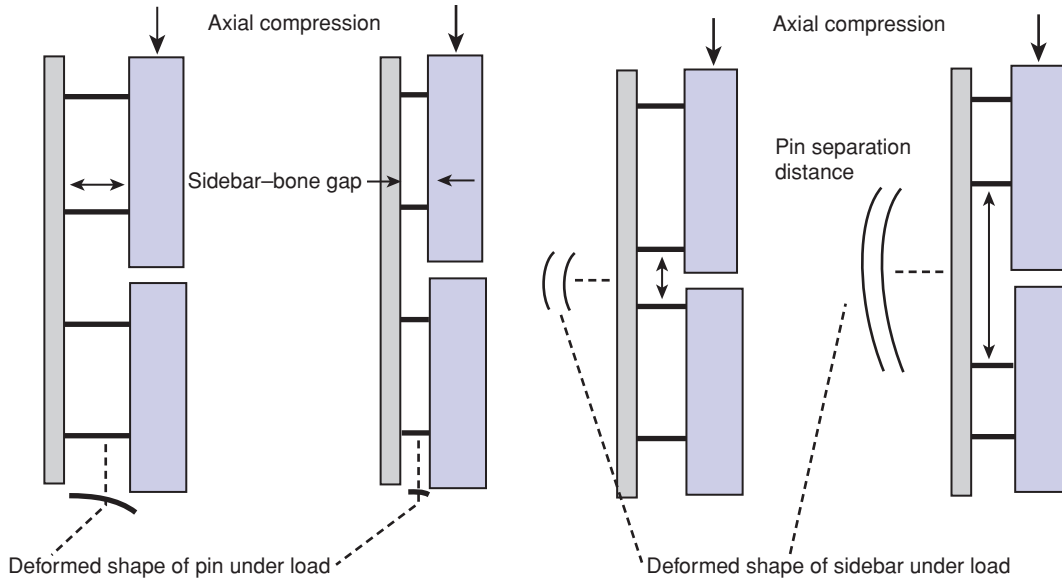

FIGURE 1-51 To produce more rigidity in the construction of an external fixator, the basic principles that should be considered are that for pin- and rod-type sidebars, stiffness increases with the fourth power of the cross-sectional area (the moment of inertia, Fig. 1-7) and decreases with the third power of their span or unsupported length (Fig. 1-44). This explains why it is beneficial to decrease the sidebar to bone distance, increase pin diameter, place pins as close together across the fracture site, and use larger diameter or multiple sidebars in frame construction.^{82,161}

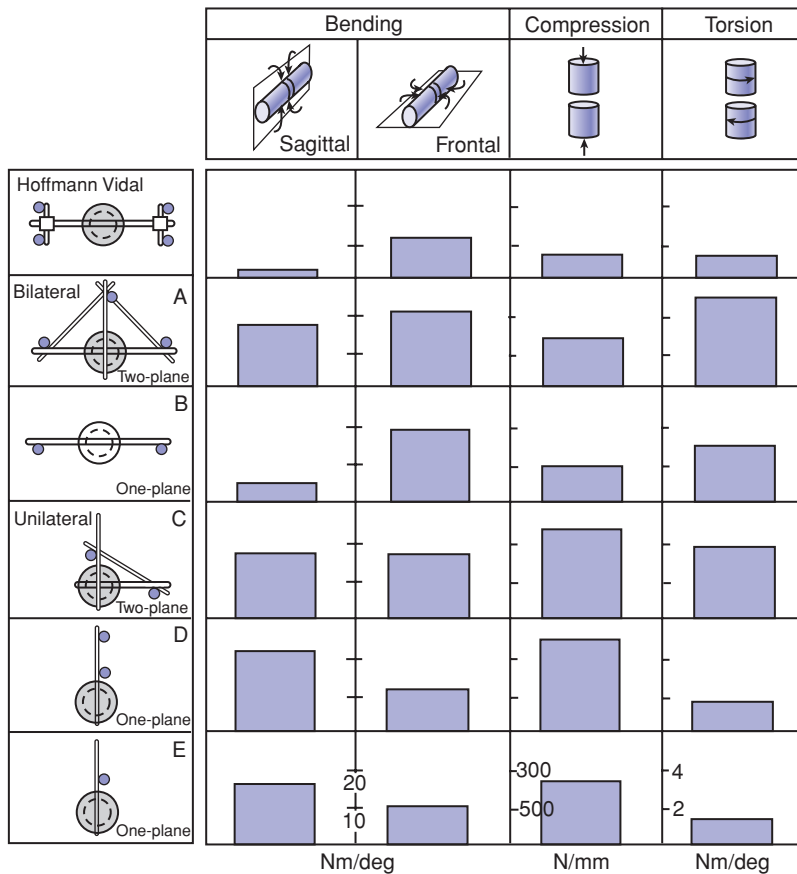

FIGURE 1-52 A comparison of the bending, compression, and torsional stiffnesses of different external fixation constructs for multiplane load resistance.²¹

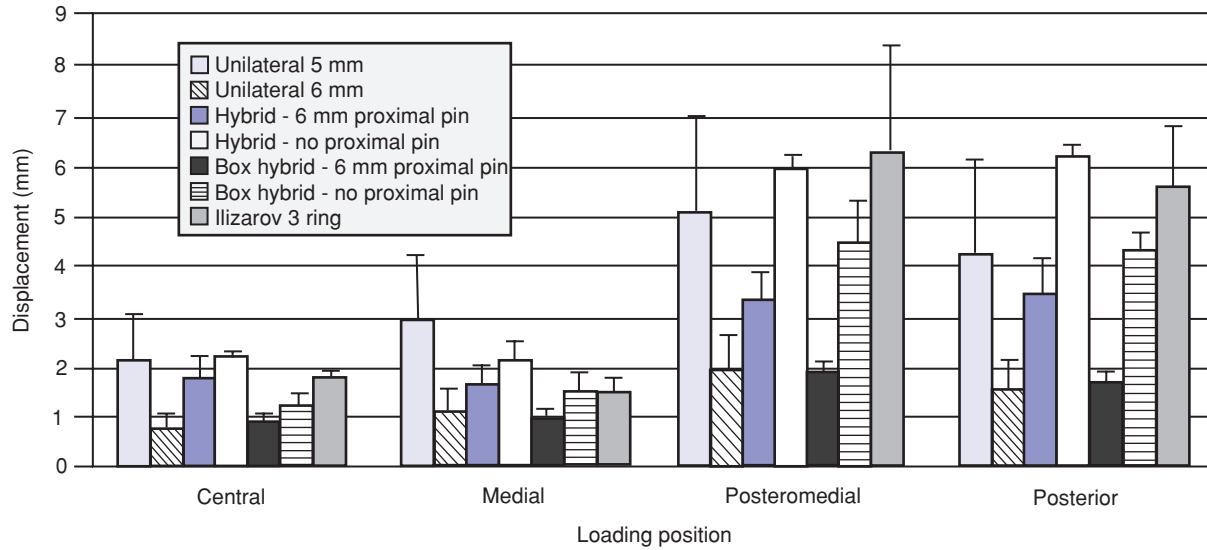

FIGURE 1-53 A comparison of displacement of the proximal fragment in a simulated tibia fracture under 100-N load with various unilateral and hybrid external fixators (the box type uses both a large unilateral frame connecting bar and two smaller diameter connecting rods).¹³⁵

pin have been found to increase anterior–posterior bending stiffness.⁶⁸ Testing of several different configurations (Fig. 1-53) revealed that the box type (two rings above and two below the fracture, along with anterior half pins, two connecting rods, and a unilateral bar) was the stiffest configuration, compared with a unilateral frame alone or a unilateral frame with rings only proximal to the fracture site. The addition of an anterior half pin significantly increased fixation stiffness.¹³⁵

Fixation in Osteoporotic Bone

The attachment strength of a fixation device to bone (e.g., a screw) is directly related to the local bone density. Since a dominant mechanical characteristic of osteoporotic bone is low den-

sity, several strategies to improve fixation strength can be used when osteoporotic bone is encountered. These include cortical buttressing by impaction; wide buttressing, which spreads the load over a larger surface area; long splintage; improved anchoring; and increasing the local bone density by injection of a denser substance such as hydroxyapatite or polymethylmethacrylate (PMMA); Figure 1-54.⁷⁶ Impaction strategies can be applied in fractures of the distal radius, femoral neck, and lumbar vertebrae. The dynamic hip screw is an example of a device which allows controlled impaction of the fracture of the femoral neck. An angled blade plate applied to supracondylar femur fractures, as compared with a condylar screw, provides wider buttressing—that is, a larger surface area of contact with

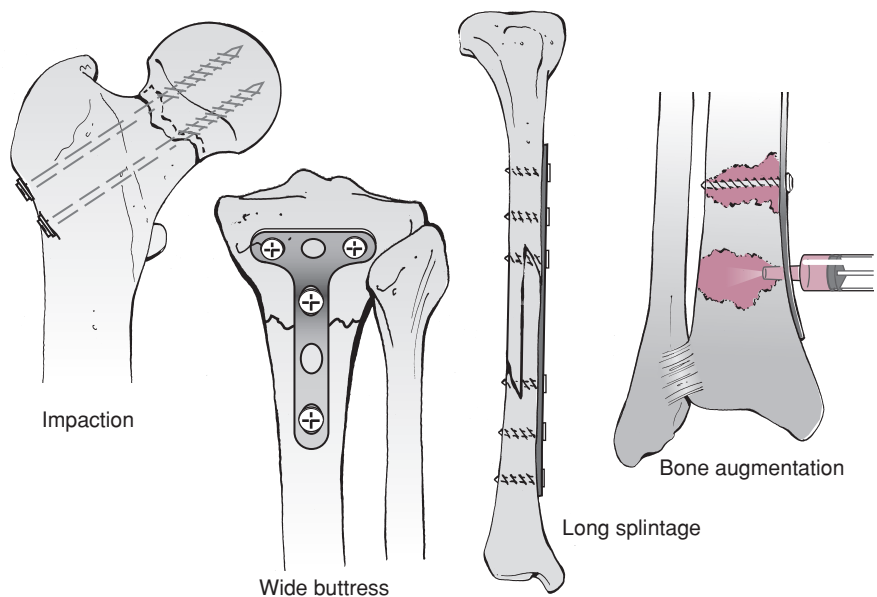

FIGURE 1-54 Some basic strategies to augment fixation strength in osteoporotic bone include impaction of the fracture components using a device that allows sliding, buttressing with a wide plate, increasing the plate length, and augmenting the bone locally by injection of methylmethacrylate or a calcium phosphate cement.⁷⁶

the bone. Splinting with a longer plate has been applied in humeral and forearm fractures, and the interlocked IM rod is another example of long splinting. A periarticular locking plate, which permits placement of multiple points of angle-stable fixation, is another example of the application of this principle.²³ The locking plate, in which the screws are threaded into the plate and fixed so they cannot rotate or translate, can be particularly useful in stabilizing osteoporotic fractures when cortical buttressing is not practical because of low bone density, and the fixation hardware must support most of the load. Hydroxyapatite-coated external fixation pins have been shown to enhance the stability of the screw–bone interface.¹²³ Interlocking screws, in which a standard screw has a 45-degree hole drilled into the shaft to accept an interlocking pin, can be used to reduce screw backout.¹¹⁴ Newer designs of IM nails also allow “angle-stable” interlocking screws that thread into the nail and create a fixed angle interface, which may improve fixation in osteoporotic bone.

Enhancement of local bone density using either PMMA or, more recently, calcium phosphate cements has been studied, particularly in relation to fixation of femoral and vertebral osteoporotic fractures. PMMA injection has been widely employed in vertebroplasty through a transpedicular approach¹⁰⁶ and has been shown to restore the stiffness of fractured vertebrae to that of intact vertebrae. Biomechanical studies have shown significantly improved strength of the fixation of femoral neck fractures up to 170%,¹⁵⁴ and similar findings, including decreased shortening and greater stability, were noted when hydroxyapatite cement was applied to unstable three-part intertrochanteric fractures fixed with a dynamic hip screw.⁵⁴ Calcium phosphate cements used in vertebroplasty instead of PMMA also restored the stiffness of fractured vertebrae to intact levels.¹⁰⁷ Calcium phosphate cement injection into the pedicle has been shown to improve the bending stiffness of pedicle screws by up to 125%.¹⁸ Calcium phosphate cements have also been shown to support elevated metaphyseal fracture fragments (i.e., in the tibial plateau) in a variety of settings in randomized clinical trials of fracture care.¹³⁸

Cerclage Wire Breakage

Cerclage wiring has been used less and less frequently for primary fracture fixation because of the negative effects of circumferential periosteal compression. However, this modality is still used occasionally, and understanding its mechanical behavior is important to avoid fixation failures. The tensile strength of surgical wire has been shown to increase directly with its diameter,¹⁵⁹ and when twisted, the optimal number of turns is between four and eight.¹⁴⁰ However, solid wire is very sensitive to notches or scratches. Testing shows that notches as small as 1% of the diameter of the wire can reduce its fatigue life by 63%.¹⁴⁰ For this reason, a cable has been introduced for cerclage applications. Cable has significantly better fatigue performance compared with wire, as shown in Figure 1-55.⁶⁹ Since cables consist of multiple strands of single thin wires, damage to any particular strand does not result in catastrophic failure of the entire cable. Single loops of suture such as Ethibond are about 30% as strong as 18-gauge stainless steel wire in tension, and Mersilene tape is approximately 50% as strong. Four loops of Ethibond have a tensile strength equivalent to stainless steel wire.⁷⁵

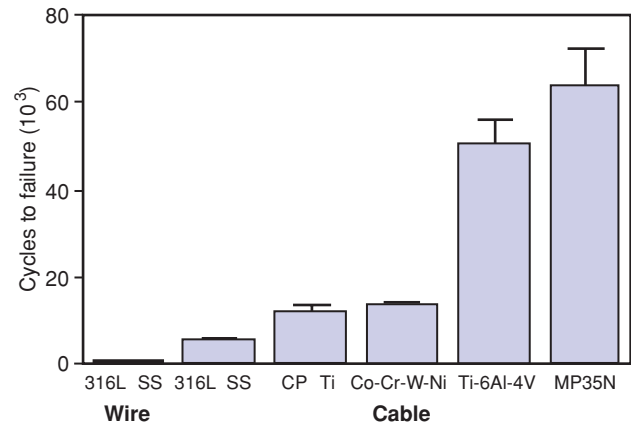

FIGURE 1-55 A comparison of the fatigue resistance of wire and cables made of the indicated materials. Wire, 316L SS (stainless steel), cable Co-Cr-W-Ni, cobalt chrome Ti-6Al-4V, titanium alloy, MP35N, nickel alloy.⁶⁹

Biomechanical Aspects of Fracture Fixation in Specific Locations

In the previous discussion, problems such as screw pullout and plate breakage common to fracture fixation, mainly in the long bones, were discussed. In this section, the focus is placed on specific challenging problems in fixation, including the femoral neck, tibial plateau, pelvis, and spine.

Fixation in the Proximal Femur

Fixation of fractures of the proximal femur is particularly challenging because the compressive force acting through the femoral head can range from four to eight times the body weight during normal activities.¹²⁷ This force acts through a significant moment arm (the length of the femoral neck), which imposes large bending loads on the fixation hardware. In addition, many of these fractures occur in the elderly, who are likely to have trabecular bone of low density and poor mechanical quality.¹⁰³ Also, it is generally not possible to gain screw purchase in the cortical bone of the femoral head.

The major force acting in a basicervical fracture of the femoral neck, fixed with a sliding hip screw, is the joint reaction force through the femoral head, which derives from body weight and forces generated by muscle action during ambulation. The joint reaction force can be divided into two components. One component (Fig. 1-56) is perpendicular to the axis of the sliding screw and causes shearing of the fracture surfaces along the fracture line, which results in inferior displacement and varus angulation of the femoral head, and increases the resistance of the screw to sliding. The other component is parallel to the screw, driving the surfaces together and enhancing stability by friction and mechanical interlocking of the fracture. Therefore, the goal of femoral neck fixation systems is to utilize the component of the joint force parallel to the femoral neck to encourage the fracture surfaces to slide together. This is the basic principle behind selection of a higher angle hip screw when possible.

When using the compression (or sliding) hip screw, or a nail with a sliding lag screw, it is important to ensure that the screw

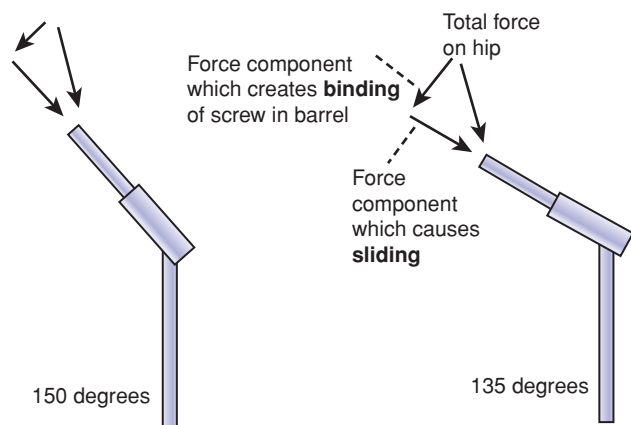

FIGURE 1-56 The joint reaction force in the femoral head can be divided into two major components. The one parallel to the axis of the femoral neck produces sliding and impaction of the fracture components and the other, transverse to the femoral neck, causes the screw component of the femoral hip screw to bind, resisting sliding. The higher-angle hip screw has a screw axis more closely aligned with the joint reaction force so the force component that produces sliding is larger whereas the transverse force component resisting sliding is smaller.

can slide freely in the barrel of the side plate or the hole in the nail. The following points related to sliding hip screw devices apply to nail/lag screw constructs as well. When screw sliding occurs, the screw is supported by the barrel against inferior bending of the femoral head because the construct is buttressed by fracture interdigitation. Adherence to two basic mechanical principles will enhance the ability of the screw to slide in the bore of the side plate or nail. As mentioned above, the higher angle hip screw is more effective at accommodating sliding. Also, the screw should be engaged as deeply as possible within the barrel. For the same force acting at the femoral end of the screw, the internal force where the screw contacts the barrel is increased if less of the screw shaft remains in the barrel. This occurs because the moment (bending load) caused by the force transverse to the axis of the screw (F_h in Fig. 1-57) at the femoral head acts over a longer moment arm or perpendicular distance, L_e (force \times perpendicular distance to the edge of the barrel, which is the fulcrum). The balancing moment arm, L_b , is shorter because less of the screw remains in the barrel. Because F_h acts over a longer moment arm while F_b acts over a shorter moment arm, F_b increases. The internal force, F_b , where the screw contacts the barrel causes a greater frictional resistance force, which requires more force to overcome friction and permit sliding.⁹⁸ Sliding hip screws with either two- or four-hole side plates appear to provide equivalent resistance to physiologic compressive loading.¹¹⁵

Several factors affect the strength of femoral neck fixation using multiple screws, but the number of screws used (three or four) is not a significant factor.¹⁶⁴ Factors that increase the strength of this type of fixation include a more horizontal fracture line with respect to the long axes of the screws,⁵⁰ placement of the screws in areas of greater femoral head bone density,^{155,158} fractures with less comminution,¹³⁶ and a shorter moment arm

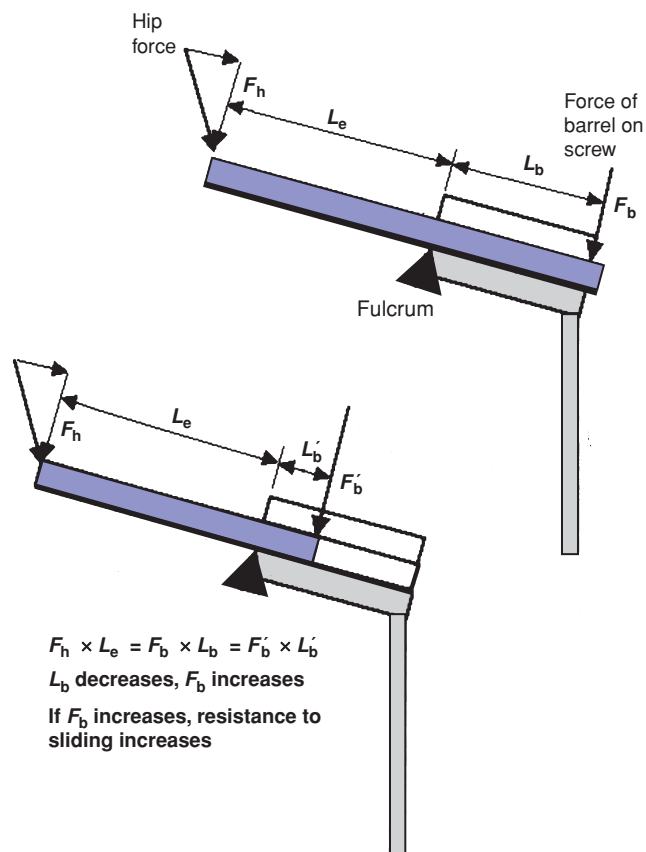

FIGURE 1-57 The greater the length of the sliding screw within the barrel, the lower its resistance to sliding. In this diagram F_h is the component of the joint reaction force perpendicular to the axis of the screw. The inferior edge of the proximal end of the barrel is the location of the fulcrum in bending. An internal force, F_b , from the surface of the barrel acts against the screw to counteract F_h . For equilibrium, the moments produced by F_h ($F_h \times L_e$) and F_b ($F_b \times L_b$) must be equal. If L_b , the distance from the point of application of internal force F_b to the fulcrum, decreases, F_b must increase to produce the same moment. If F_b is larger, the frictional force and therefore the resistance to screw sliding will increase. (L_e is the length of the screw beyond the barrel).⁹⁸

for the joint load (shorter distance from the center of the femoral head to the fracture line).¹⁵⁵ However, the most important factor has been found to be the quality of the reduction because of the importance of cortical buttressing in reducing fracture displacement.¹⁵² Under physiologic load, several mechanisms of failure of fixation have been observed (Fig. 1-58). In some cases the screws bend inferiorly, especially if buttressing of the fracture surfaces inferior to the screws is not possible because of comminution of the fracture. The screw heads, if no washers are used to distribute the screw load against bone, have been found to pull through the cortex near the greater trochanter when the cortex is thin. Finally, if the screws are not well supported inferiorly where they cross the fracture, they may rotate inferiorly carrying the femoral head into a varus orientation.¹⁵⁵ Supporting at least one screw against the inferior cortex, which is an established clinical technique, may help prevent this from occurring.

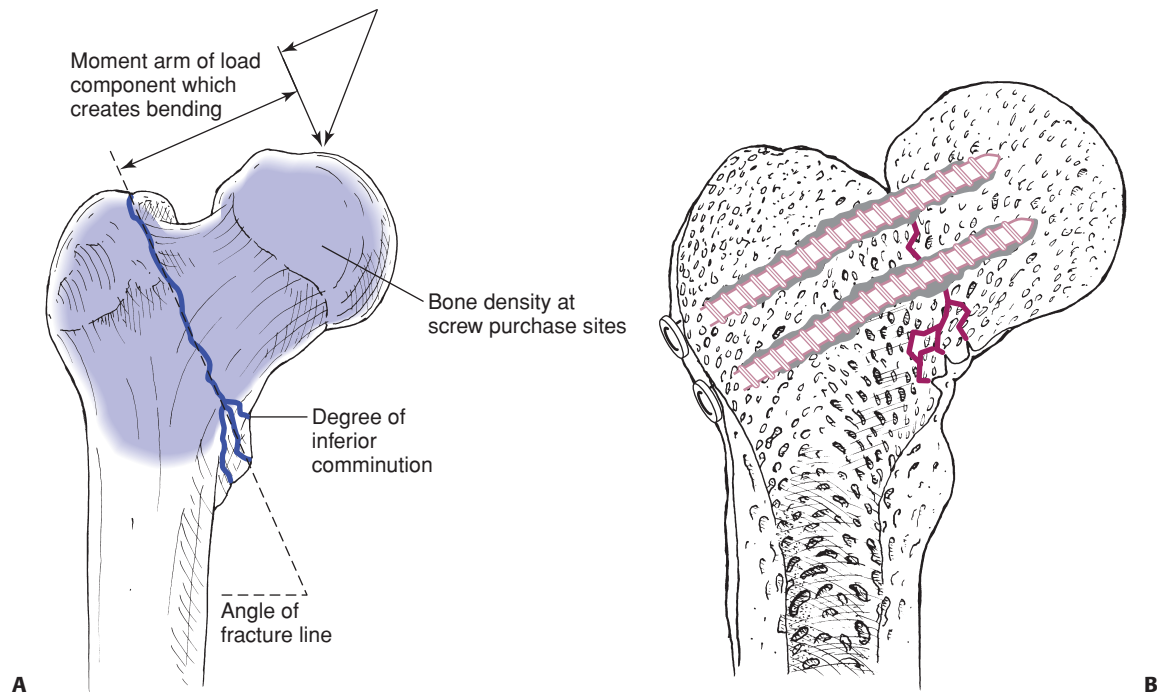

FIGURE 1-58 A: Some factors that decrease the strength of femoral neck fracture fixation include decreased bone density, a more vertical fracture surface (which facilitates sliding of the fracture components), comminution at the inferior cortex (which reduces buttressing against bending), and a longer moment arm or distance of the center of the femoral head to the fracture line. **B:** Observed mechanisms of failure of femoral neck fixation using screws include bending of the pins, displacement of the screw heads through the thin cortex of the greater trochanter, especially if washers are not used, and rotation of the screws inferiorly through the low-density cancellous bone of the Ward triangle area until they settle against the inferior cortex.¹⁵⁵

With respect to the biomechanical performance of different devices, the actual stiffness provided by the sliding hip screw, the reconstruction nail, and multiple pin constructs are quite similar, except for significantly greater torsional stiffness of the reconstruction nail because of its tubular shape.^{71,137} New techniques applied to proximal fracture fixation include the femoral locking plate and percutaneous compression plating. In fixation of the challenging vertical shear fracture of the proximal femur, the proximal femoral locking plate was found to produce considerably stiffer constructs than cannulated screws, a dynamic hip screw, or a dynamic condylar screw.⁶ However, clinical series describing the use of the proximal femoral locking plate have demonstrated unacceptably high rates of failure, illustrating the dangers of relying solely on biomechanical data when choosing an implant.^{19,156} Percutaneous compression plating has been found to provide adequate bending and torsional stability⁹⁷ and was equivalent to the trochanteric antegrade nail in fracture site stability, though it failed at about 2,100 N (about three times the body weight) compared with the antegrade nail at 3,200 N.⁷²

Fixation Around the Metaphyseal Region of the Knee

Both supracondylar femur and tibial plateau fractures are challenging to stabilize because they often involve fixation

of multiple small fragments of primarily cancellous bone. Supracondylar fixation alternatives that have been compared mechanically include condylar plates, plates with lag screws across the fracture site, and blade plates. All devices tested appeared to provide similar construct stiffnesses. The most important factor identified for plate fixation was maintaining contact at the cortex opposite to which the fixation device was applied. Fixation constructs without cortical contact were only 20% as stiff as those with cortical buttressing.^{61,149} Using a retrograde IM supracondylar nail was found to produce constructs that were 14% less stiff in axial compression and 17% less stiff in torsion, compared with a fixed angle side plate.¹¹⁸ However, longer nails (36 cm) enhanced fixation stability compared with shorter nails (20 cm).¹⁵³ Several newer fixation systems have been described for femoral supracondylar fracture stabilization. The less invasive stabilization system (LISS) uses a low-profile plate with monocortical screws distally, which also lock to the plate. LISS plates produced constructs with more elastic deformation and less subsidence than those with a condylar screw or buttress plate.^{110,165}

Tibial plateau fractures are challenging to stabilize. Considering patient outcomes, risk factors for loss of reduction have been shown to include patients aged greater than 60 years old, premature weight bearing, fracture comminution, and severe osteoporosis.³ Different methods of fixation include wires or

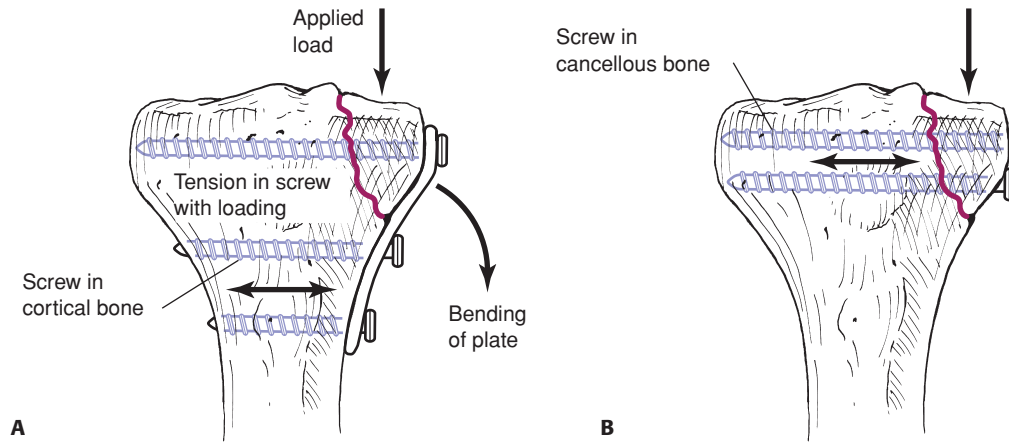

FIGURE 1-59 Two alternative methods of fixation of tibial plateau fractures: **(A)** transverse screws combined with a buttress plate and **(B)** transverse screws alone. The buttress plate provides additional support in bending as the tibial fracture component is loaded in an inferior direction and allows the screws to engage the thicker, more distal cortical bone.

screws alone (Fig. 1-59) or screws placed through an L- or T-shaped plate, buttressing the cortex. Various configurations of wires have been tested²⁵ and show that the stiffness of the construct increases with the number of wires, regardless of their specific orientations. As Figure 1-59 shows, fixation with screws alone requires that the screws resist bending forces as the tibial fragment is loaded distally in compression through the joint. With the addition of a plate, not only is the load distributed to the plate, but also additional screws can be placed in the stronger cortical bone distal in the metaphyseal region of the tibia. One disadvantage of a buttress plate is the soft tissue stripping required for application with potential for blood supply compromise. Fixation with T plates and screws showed the greatest resistance to an axial compressive load,⁴⁸ regardless of the specific configuration of the screws.⁸⁹ Investigations of different plate configurations found that for bicondylar tibial plateau fractures, dual (lateral and medial) side plating reduced subsidence under axial loading by about 50% compared with single-sided lateral locking plating.⁷⁷ For medial plateau fractures, the medial buttress plate, which supports the load directly, is significantly superior mechanically to a lateral locked plate.¹³³ A new alternative is a short proximal tibial nail with multiple interlocking screws. In combined axial loading, bending and rotation, the nail provided stability equivalent to that of double plating and was greater than constructs with a locking plate, external fixator, or conventional unreamed tibial nail.⁷⁴ This device may be applicable for cases without significant proximal (joint) comminution.

Fixation of the Spine

The halo apparatus is an external fixation device for cervical spine injuries that are stable in compression. It stabilizes the injured cervical spine mainly in bending but not in compression. Factors that affect its mechanical performance include (Fig. 1-60) the fit of the jacket on the torso and the frictional characteristics of the lining. High friction linings decrease slip

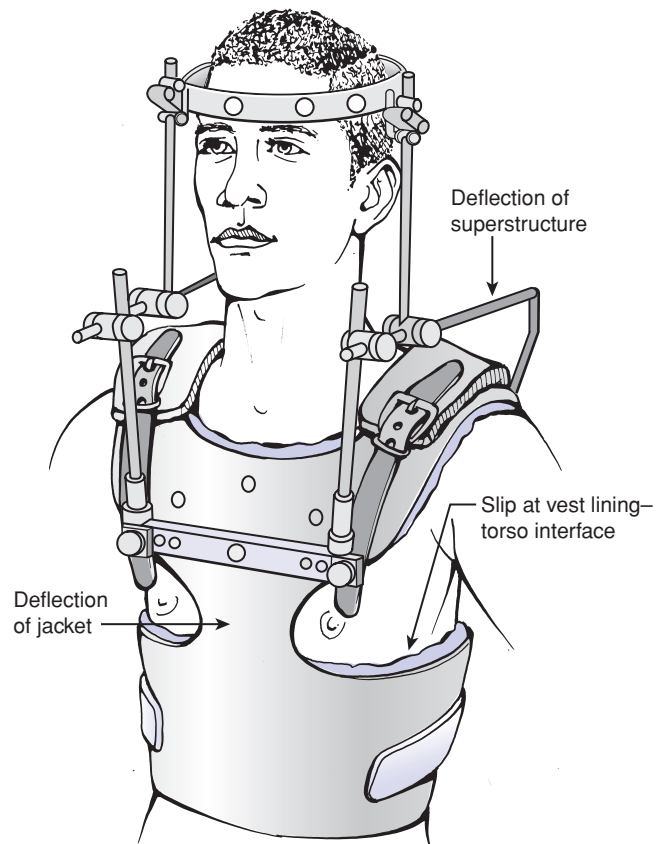

FIGURE 1-60 A schematic diagram showing possible sources of deformation in the halo apparatus. The large distance from the vest to chest contact points to the cervical injury site results in relatively large motions at the injury site for small motions of the vest.¹²⁰

at the vest lining/torso interface, more rigid vests reduce deflection under loads, and less flexible superstructures all decrease cervical spine motion at the injury level. Although stiffening the vest enhances its ability to stabilize the injury, this property must be balanced with enough flexibility to provide reasonable comfort for the wearer and to accommodate expansion and contraction of the chest. Since the injured cervical segment is relatively distant from the vest, small motions of the vest can result in relatively large displacements at the injury site.¹²⁰ A very rigid halo superstructure attaching the vest to the halo ring may not increase injury stability if connected to a poorly fitting vest.

Several methods are available to reconstruct cervical spine injuries. The major differences between them relate to the location of the fixation device itself on the vertebra— anterior, lateral, or posterior—and to the method by which the fixation is attached to the bone. Generally, the most rigid fixation is the one with the longest moment arm from the center of rotation of the injured segment. For a specific applied moment, such as flexion, a posteriorly located fixation, being located farther from the center of rotation, results in greater rigidity. Figure 1-61 shows the approximate locations of the centers of rotation at different cervical spine levels when the posterior elements have been disrupted.⁵ After corpectomy, biomechanical testing has shown that posterior rods provide the greatest stability, which is unchanged after augmentation with an anterior plate, whereas anterior plating alone offers the least stability.¹⁵⁰ Similarly, another test showed that after corpectomy, sagittal plane motion was most rigid after supplementation with lateral mass plates, less rigid with an anterior plate alone, and least with strut grafting alone.⁹⁰ Anterior plates provide relatively similar stability, especially if augmented with a bone graft; however, with multilevel corpectomy, anterior plate constructs were more prone to fatigue loosening than single-level corpectomies.⁸⁴ Newer semiconstrained anterior plates, most of which offer devices to lock the screws to prevent back out, allow screw rotation which results in more load sharing with the graft.¹³¹ By comparison, the compressive load estimated to be transmitted through the graft increased from 40% with a fully constrained device to 80% when a semiconstrained device was used.¹³¹ Wiring or plating with lateral mass screws generally reduces anterior–posterior motion across the fixed segment by 20% to 70%, so none of these techniques can be considered as entirely rigid.¹¹⁹

The type of attachment of the fixation system to the vertebra is fundamental to its performance. Wires, hooks, screws, or combinations, all produce different types of force transfer between the fixation and the vertebra (Fig. 1-62).³⁸ A wire can resist only tension, whereas a screw can resist forces in all directions (tension, compression, bending transverse to the axis of the screw) except for rotation about its longitudinal axis. A hook only resists forces that drive the surface of the hook against the bone, and depends on the shape of the hook and the bone surface it rests against. For this reason, screws are biomechanically superior to other forms of vertebral attachments.

In general, pedicle screws resist pullout in the same manner as bone screws described elsewhere. Therefore the pull-

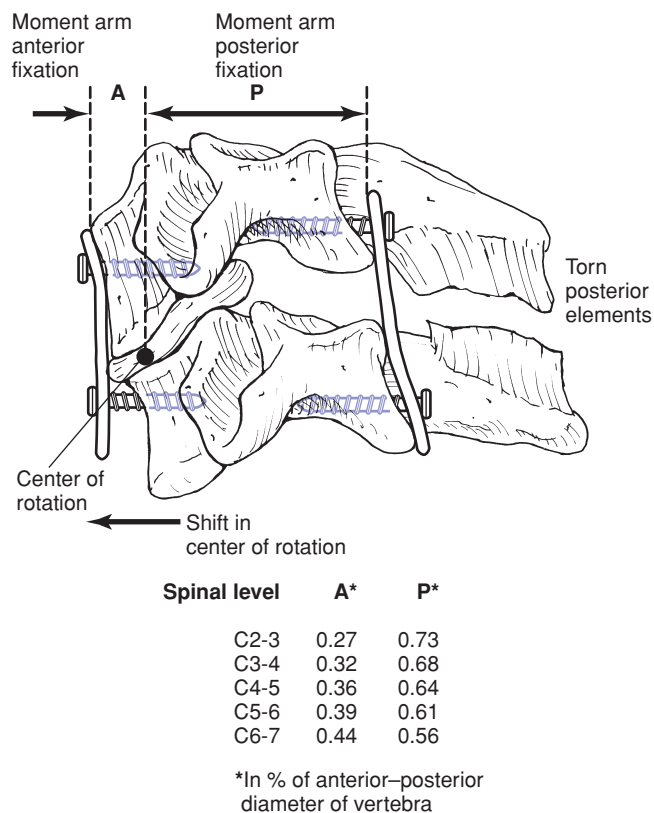

FIGURE 1-61 The ratios, in terms of anterior–posterior diameter of the vertebra, of the location of the center of rotation at each vertebral level, from the anterior and posterior surfaces. A fixation device must resist bending moments caused by flexion, extension, lateral bending, and torsion. The resisting moment in the fixation is the product of the force acting in the fixation (e.g., at the screw–plate junction) and the distance of that point on the fixation to the center of rotation of the motion segment. The longer the moment arm for the same bending load, the smaller the force on the fixation components. Posterior fixation, by its location, will have lower moments in its components.⁵

out strength increases with increasing density of the bone it is embedded into,^{35,109,170,173} a greater depth of insertion,¹⁰⁰ engagement of the anterior cortex,¹²¹ and a larger screw diameter. Single screws placed into pedicles and loaded in a caudal–cephalad direction (which occurs during flexion and extension of the vertebra) are vulnerable to toggling, and eventual loosening, even under relatively small forces. As demonstrated in Figure 1-63, the screw tends to toggle about the base of the pedicle, which is the stiffest region as it mainly comprises cortical bone. Toggling tends to enlarge the screw hole in a “windshield wiper” fashion.^{13,100} Toggling can be reduced if the screw head is locked to the plate or rod, and the plate or rod contacts the vertebra over a wide area.¹⁰⁰

Some fundamental principles should be considered when applying lumbar spinal fixation. Longer fixation, attached to more vertebrae, reduces forces acting on the screws because of the effect of the greater lever arm of a longer plate or rod. A longer fusion, although biomechanically advantageous, is

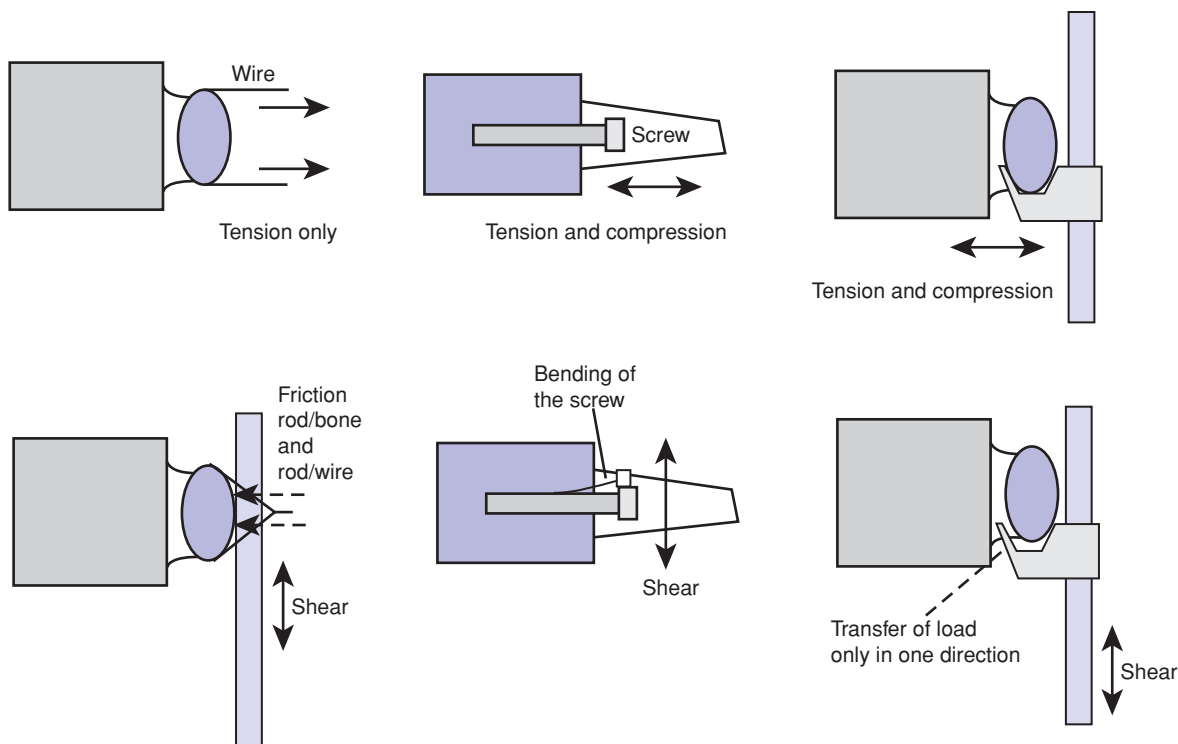

FIGURE 1-62 Comparisons of the forces that can be resisted by different methods of attachment of the fixation to the vertebra. A sublaminar wire resists only tension, whereas a screw can resist forces in all directions except for rotation about its long axis. A hook resists only forces that drive it against the bone surfaces.

not necessarily beneficial from a clinical perspective because the remaining spinal motion is significantly reduced. Adding an anterior strut graft or a fusion cage is important because it buttresses a posterior fixation system against flexion moments, reducing forces in the fixation.⁹⁴ Coupler bars, which connect

the fixation rods to form an H configuration, prevent the rods from rotating medially or laterally when torsion is applied to the motion segment, as shown in Figure 1-64. This significantly enhances the torsional and lateral bending stability of the implant.⁷⁷

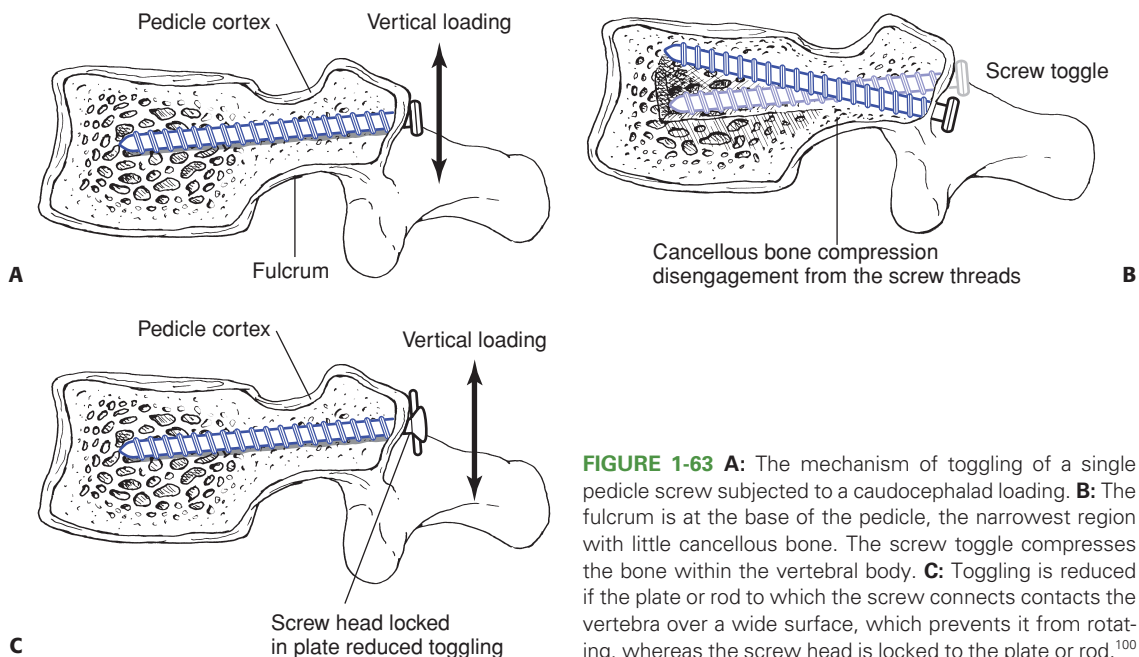

FIGURE 1-63 **A:** The mechanism of toggling of a single pedicle screw subjected to a caudocephalad loading. **B:** The fulcrum is at the base of the pedicle, the narrowest region with little cancellous bone. The screw toggle compresses the bone within the vertebral body. **C:** Toggling is reduced if the plate or rod to which the screw connects contacts the vertebra over a wide surface, which prevents it from rotating, whereas the screw head is locked to the plate or rod.¹⁰⁰

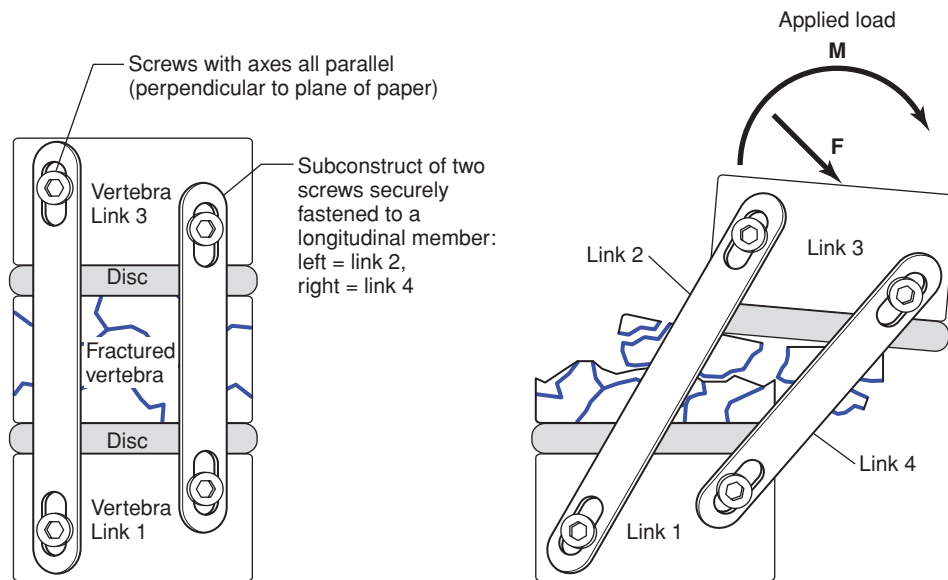

FIGURE 1-64 Without a coupler bar between two longitudinal rods (**left**), they can rotate when a lateral moment or axial torsion is applied (**right**). A coupler connecting the rods to form an H configuration reduces this effect.⁷⁷

Extensive testing has been performed on various posterior and anterior thoracolumbar fixation devices as they continue to be developed. Testing of anterior fixation systems with and without an augmented strut graft showed that load sharing with the graft ranged from 63% to 89% for six systems tested, three being plates and three based on locked rods. These tests demonstrated the significant effect of the graft in sagittal plane stability. The most rigid systems relied on either a thick rigid plate or large rods, although this may not correlate with clinical performance.²⁸ In cases of delayed or nonunion, the cyclic performance of the implant can be very important, more so than its static stiffness or maximum load to failure. A comparison test of 12 fixation systems showed that only three could withstand two million load cycles with 600 N of compressive force. The two constructs with the greatest bending strength did not fail after cycling. However, there was no correlation between bending strength and cyclic failure for the other 10 systems, indicating that particular design aspects could cause fatigue failure regardless of static strength.⁹³ Three devices failed in less than 10,000 cycles. Currently, most posterior devices use essentially the same principles, including pedicle screws with an interface clamp to the rod that allows variable orientation of the screw, a low-profile assembly, and crosslinks. They provide similar fixation stiffness. Lumbosacral fixation using sacral screws was most rigid and demonstrated the least screw strain when supplemented with iliac screws, and was more effective than using screws at S1 supplemented with screws at S2.¹⁰¹

The biomechanical properties of fusion cages have been investigated. A fusion cage is a hollow threaded insert that can be applied from anterior, lateral, or posterior directions in single or double units. Various fusion cages are available for the cervical spine. The devices fall into one of three categories: screw designs with a horizontal cylinder and external threads, box shapes, and vertical cylinders. In general, all cage designs increased flexion stiffness by 130% to 180%. Only a few box or

cylinder designs increased extension stiffness, and box designs were most effective in increasing axial rotation and lateral bending stiffnesses, ranging from 140% to 180% of intact values.⁸⁷ Testing of lumbar fusion cages has shown that placement of cages in lateral, posterolateral, or posterior orientations had little effect on stiffness. The exception was for torsional loading with posterior cage placement because posterior insertion damaged the lamina or facets, thus reducing the inherent torsional stability of the motion segment. Fixation with cages alone did not significantly increase lumbar motion segment stability, so augmentation with posterior fixation in cases of motion segment instability is necessary. Because cage fixation relies on the combination of distraction of the soft tissues and the strength of the vertebral cancellous bone, the properties of these tissues will have a significant effect on the performance of cage implant constructs.¹⁶²

Fixation of the Humerus

Proximal humerus fractures fixed with locking plates provided greater stability against torsional loading, but were similar to blade plate constructs in bending, because both fixation devices are loaded as tension bands in bending.^{122,145,146} In comparing different types of blade plate constructs, the stiffest construct employed an eight-hole, low-contact dynamic compression plate, contoured into a blade configuration, and fixed with a diagonal screw that triangulates with the end of the blade. This arrangement was considerably stiffer than other blade plates or T plate and screw constructs.¹⁰⁵ One potential problem is penetration of the screws through the subchondral bone in osteoporotic patients. Because of the stiffness of the locking plate-screw construct, if there is any “settling” of the fracture site the locking screws may penetrate into the joint. The incidence of intra-articular screw penetration with proximal humeral locking plates is considerably higher than with conventional implants.⁵²

SUMMARY

Effective fracture fixation requires a biomechanical appreciation of the forces applied to a damaged bone or joint and the basic mechanisms by which these loads are transferred through the bridging fixation and the implant–bone interface. In particular, the importance of the contribution of cortex-to-cortex contact across the fracture site in resisting both compressive and bending forces must be emphasized. This contact creates a buttress that contributes significantly to the stability of the construct and the functional life of the implant. Many of the observations used to formulate these basic principles have been made using cadaveric bone in experimental laboratory simulations, and conclusions are based on comparisons of the most rigid mechanical construct. Other aspects such as the compromise of blood flow or the extent of the incision during installation should also be considered. Further, even if one construct is more rigid than another, within a certain range of mechanical stiffness, both may perform equally well in producing fracture healing with anatomic alignment. It is important to correlate biomechanical information with clinical observations of the performance of the implant during fracture healing.

REFERENCES

- Aharonoff GB, Dennis MG, Elshinawy A, et al. Circumstances of falls causing hip fractures in the elderly. *Clin Orthop Rel Res.* 1998;348:10–14.
- Alho A, Husby T, Hoiseth A. Bone mineral content and mechanical strength. An ex vivo study on human femora at autopsy. *Clin Orthop Rel Res.* 1988;227:292–297.
- Ali AM, El-Shafie M, Willett KM. Failure of fixation of tibial plateau fractures. *J Orthop Trauma.* 2002;16:323–329.
- Allgower M. Cinderella of surgery-fractures? *Surg Clin North Am.* 1978;58:1071–1093.
- Amevo B, Aprill C, Bogduk N. Abnormal instantaneous axes of rotation in patients with neck pain. *Spine.* 1992;17:748–756.
- Aminian A, Gao F, Fedoriw WW, et al. Vertically oriented femoral neck fractures: Mechanical analysis of four fixation techniques. *J Orthop Trauma.* 2007;21:544–548.
- Antekeier SB, Burden RL, Voor MJ, et al. Mechanical study of the safe distance between distal femoral fracture site and distal locking screws in antegrade intracondylar nailing. *J Orthop Trauma.* 2005;19:693–697.
- Aro HT, Wippenman BW, Hodgson SF, et al. Prediction of properties of fracture callus by measurement of mineral density using microbone densitometry. *J Bone Joint Surg Am.* 1989;71A:1020–1030.
- Ascenzi A, Bonucci E. The tensile properties of single osteons. *Anat Rec.* 1967;158:375–386.
- Ascenzi A, Bonucci E. The compressive properties of single osteons. *Anat Rec.* 1968;161:377–392.
- Ascenzi A, Bonucci E. The shearing properties of single osteons. *Anat Rec.* 1972;172:499–510.
- Ascenzi A, Bonucci E, Simkin A. An approach to the mechanical properties of single osteonic lamellae. *J Biomech.* 1973;6:227–235.
- Ashman RB, Galpin RD, Corin JD, et al. Biomechanical analysis of pedicle screw instrumentation in a corpectomy model. *Spine.* 1989;14:1398–1405.
- Askew MJ, Mow VC, Wirth CR, et al. Analysis of the intraosseous stress field due to compression plating. *J Biomech.* 1975;8:203–212.
- Assal M, Huber P, Rohr E, et al. Are drivers more likely to injure their right or left foot in a frontal car crash: A car crash and biomechanical investigation. *46th Annual Proceedings, Association for the Advancement of Automotive Medicine.* 2002:273–288.
- Augat P, Merk J, Wolf S, et al. Mechanical stimulation by external application of cyclic tensile strains does not effectively enhance bone healing. *J Orthop Trauma.* 2001;15:54–60.
- Ayerby SA, Ehteshami JR, McLain RF. Offset laminar hooks decrease bending moments of pedicle screws during in situ contouring. *Spine.* 1997;22:376–381.
- Bai B, Kummer FJ, Spivak J. Augmentation of anterior vertebral body screw fixation by an injectable biodegradable calcium phosphate bone substitute. *Spine.* 2001;24:2679–2683.
- Berkes MB, Little MT, Lazaro LE, et al. Catastrophic failure after open reduction internal fixation of femoral neck fractures with a novel locking plate implant. *J Orthop Trauma.* 2012;26:e170–e176.
- Bartley MH Jr, Arnold JS, Haslam RK, et al. The relationship of bone strength and bone quantity in health, disease, and aging. *J Gerontol.* 1996;21:517–521.
- Behrens F, Johnson WD. Unilateral external fixation methods to increase and reduce frame stiffness. *Clin Orthop Rel Res.* 1989;241:48–56.
- Bell GH, Dunbar O, Beck JS, et al. Variations in strength of vertebrae with age and their relation to osteoporosis. *Calcif Tissue Res.* 1967;1:75–86.
- Benirschke SK, Swiontkowski MF. Knee. In: Hansen ST, Swiontkowski MF, eds. *Orthopedic Trauma Protocols.* New York, NY: Raven Press, 1993.
- Benjamin J, Bried J, Dohm M, et al. Biomechanical evaluation of various forms of fixation of transverse patellar fractures. *J Orthop Trauma.* 1987;1:219–222.
- Beris AE, Glisson RR, Seaber AV, et al. Load tolerance of tibial plateau depressions reinforced with a cluster of K-wires. Paper presented at: 34th Annual Meeting of the Orthopedic Research Society; March 7–10, 1988; Atlanta, CA.
- Black J. *Orthopedic Biomaterials in Research and Practice.* New York, NY: Churchill Livingstone; 1988.
- Bottlang M, Lesser M, Koerber J, et al. Far cortical locking can improve healing of fractures stabilized with locking plates. *J Bone Joint Surg Am.* 2010;92(7):1652–1660.
- Brodke DS, Golligly S, Bachus KN, et al. Anterior thoracolumbar instrumentation: Stiffness and load sharing characteristics of plate and rod systems. *Spine.* 2003;1794–1801.
- Brooks DB, Burstein AH, Frankel UH. The biomechanics of torsional fractures. *J Bone Joint Surg Am.* 1970;52A:507–514.
- Buchholz RW, Ross SE, Lawrence KL. Fatigue fracture of the interlocking nail in the treatment of fractures of the distal part of the femoral shaft. *J Bone Joint Surg Am.* 1987;69A:1391–1399.
- Burstein AH, Reilly DL, Martens M. Aging of bone tissue: Mechanical properties. *J Bone Joint Surg Am.* 1976;58A:82–86.
- Burstein AH, Zika IM, Heiple KG, et al. Contribution of collagen and mineral to the elastic-plastic properties of bone. *J Bone Jt Surg Am.* 1975;57A:956–961.
- Calhoun JH, Li F, Ledbetter BR, et al. Biomechanics of Ilizarov for fracture fixation. Paper presented at: 37th Annual Meeting of the Orthopedic Research Society; March 4–7, Anaheim, CA.
- Carter DR, Hayes WC. The compressive behavior of bone as a two-phase porous structure. *J Bone Joint Surg Am.* 1977;59A:954–962.
- Chapman JR, Harrington RM, Lee KM, et al. Factors affecting the pullout strength of cancellous bone screws. *ASME J Biomech Eng.* 1996;118:391–398.
- Clark CR, Morgan C, Sonstegard DA, et al. The effect of biopsy-hole shape and size on bone strength. *J Bone Joint Surg Am.* 1977;59A:213–217.
- Cody DD, Goldstein SA, Flynn MJ, et al. Correlations between vertebral regional bone mineral density (rBMD) and whole bone fracture load. *Spine.* 1991;16:146–154.
- Coe JD, Herzog MA, Warden KE, et al. Load to failure of spinal implants in osteoporotic spines: a comparison of pedicle screws, laminar hooks, and spinous process wires. Paper presented at: 35th Annual Meeting of the Orthopedic Research Society; March 1–4, Las Vegas, NV.
- Cordey J, Florin P, Klaue K, et al. Compression achieved with the dynamic compression plate: Effects of the inclined sloping cylinder and inclination of the screw. In: Uthoff HK, ed. *Current Concepts of Internal Fixation of Fractures.* Berlin: Springer-Verlag; 1980:192–200.
- Crowninshield RD, Pope MH. The response of compact bone in tension at various strain rates. *Ann Biomed Eng.* 1974;2:217–225.
- Currey JD. The mechanical consequences of variation in the mineral content of bone. *J Biomech.* 1969;2:1–11.
- Currey JD. The effects of strain rate, reconstruction, and mineral content on some mechanical properties of bovine bone. *J Biomech.* 1975;8:81–86.
- Currey JD. Changes in the impact energy absorption of bone with age. *J Biomech.* 1979;12:459–469.
- Currey JD. *The Mechanical Adaptation of Bones.* Princeton, NJ: Princeton University Press; 1984.
- Currey JD, Butler G. The mechanical properties of the bone tissue in children. *J Bone Joint Surg Am.* 1975;57A:810–814.
- Dalen N, Hellstrom LG, Jacobson B. Bone mineral content and mechanical strength of the femoral neck. *Acta Orthop Scand.* 1976;47:503–508.
- DeCoster TA, Heetderks DB, Downey DJ, et al. Optimizing bone screw pullout force. *J Orthop Trauma.* 1990;4:169–174.
- Denny LD, Keating EM, Engelhardt JA, et al. A comparison of fixation techniques in tibial plateau fractures. Paper presented at: 30th Annual Meeting of the Orthopedic Research Society; February 6–9, Atlanta, GA.
- Edgerton BC, An K-A, Morrey BF. Torsional strength reduction due to cortical defects in bone. *J Orthop Res.* 1990;8:851–855.
- Edwards WT, Lewallen DG, Hayes WC. The effect of pin number and fracture pattern on immediate mechanical fixation of a subcapital hip fracture model. Paper presented at: 31st Annual Meeting of the Orthopedic Research Society; February 19–22, Las Vegas, NV.
- Egol KA, Chang EY, Cvitkovic J, et al. Mismatch of current intramedullary nails with the anterior bow of the femur. *J Orthop Trauma.* 2004;18:410–415.
- Egol KA, Kubiak EN, Fulkerson E, et al. Biomechanics of locked plates and screws. *J Orthop Trauma.* 2004;18:488–493.
- Ehmke LW, Polzin BMI, Madey SM, et al. Femoral nailing through the trochanter: The reamer pathway indicates a helical shaped nail. *J Orthop Trauma.* 2006;20:668–674.
- Elder S, Frankenberg E, Yetkilner DN, et al. Biomechanical evaluation of calcium phosphate cement augmented fixation of unstable intertrochanteric fractures. Paper presented at: 43rd Annual Meeting of the Orthopedic Research Society; March 16–19, New Orleans, LA.
- Ellis T, Bourgeault CA, Kyle RF. Screw position affects dynamic compression plate strain in an in vitro fracture model. *J Orthop Trauma.* 2001;15:333–337.
- El Maraghy AW, Elmaraghy MW, Nousiainen M, et al. Influence of the number of cortices on the stiffness of plate fixation of diaphyseal fractures. *J Orthop Trauma.* 2001;15:186–191.
- Evans FG. Relations between the microscopic structure and tensile strength of human bone. *Acta Anat.* 1958;35:285–301.
- Evans FG, Bang S. Differences and relationships between the physical properties and the structure of human femoral, tibial, and fibular cortical bone. *Am J Anat.* 1967;120:79–88.
- Evans FG, Vincentelli R. Relation of collagen fiber orientation to some mechanical properties of human cortical bone. *J Biomech.* 1969;2:63–71.
- Finlay JB, Jarada I, Boune RB, et al. Analysis of the pull-out strength of screws and pegs used to secure tibial components following total knee arthroplasty. *Clin Orthop Rel Res.* 1989;247:220–231.

61. Frankenburg EP, Robinson AP, Urquhart AG, et al. Supracondylar femur fractures: A biomechanical analysis of four fixation devices. Paper presented at: 38th Annual Meeting of the Orthopedic Research Society; February 17–20, Washington, DC.
62. Frigg R, Appenzeller A, Christensen R, et al. The development of the distal femur Less Invasive Stabilization System (LISS). *Injury*. 2001;32:S-C-24–S-C-31.
63. Funk JR, Tourret LJ, George SE, et al. The role of axial loading in malleolar fractures. *SAE Transactions*. 2000–01–0155, 2000.
64. Galante J, Rostoker W, Ray RD. Physical properties of trabecular bone. *Calcif Tissue Res*. 1970;5:236–246.
65. Gardner MJ, Nork SE, Huber P, et al. Stiffness modulation of locking plate constructs using near cortical slotted holes: A preliminary study. *J Orthop Trauma*. 2009;23(4):281–287.
66. Gardner MJ, Nork SE, Huber P, et al. Less rigid stable fracture fixation in osteoporotic bone using locked plates with near cortical slots. *Injury*. 2010;41(6):652–656.
67. Gardner MJ, Silva MJ, Krieg JC. Biomechanical testing of fracture fixation constructs: variability, validity, and clinical applicability. *J Am Acad Orthop Surg*. 2012;20:86–93.
68. Geller J, Tornetta P III, Tiburzi D, et al. Tension wire position for hybrid external fixation of the proximal tibia. *J Orthop Trauma*. 2000;14:502–504.
69. Georgette FS, Sander TW, Oh I. *The fatigue resistance of orthopedic wire and cable systems*. Washington, DC: Second World Congress on Biomaterials; 1984:146.
70. Goldman MW, MacLennan PA, McGwin G, et al. The association between restraint system and upper extremity injury after motor vehicle collisions. *J Orthop Trauma*. 2005;19:529–534.
71. Goodman SB, Davidson JA, Locke L, et al. A biomechanical study of two methods of internal fixation of unstable fractures of the femoral neck. *J Orthop Trauma*. 1992;6:66–72.
72. Gotfried Y, Cohen B, Rotem A. Biomechanical evaluation of the percutaneous compression plating system for hip fractures. *J Orthop Trauma*. 2002;16:644–650.
73. Gotzen L, Hutter J, Haas N. The prebending of AO plates in compression osteosynthesis. In: Ulthoff HK, ed. *Current Concepts of Internal Fixation of Fractures*. Berlin: Springer-Verlag; 1980:201–210.
74. Hansen M, Mehler D, Hessmann MH, et al. Intramedullary stabilization of extra-articular proximal tibial fractures: A biomechanical comparison of intramedullary and extramedullary implants including a new proximal tibial nail (PTN). *J Orthop Trauma*. 2007;21:701–709.
75. Harrell RM, Tong J, Weinhold PS, et al. Comparison of the mechanical properties of different tension band materials and suture techniques. *J Orthop Trauma*. 2003;17:119–122.
76. Hertel R, Jost B. Basic principles and techniques of internal fixation in osteoporotic bone. In: Yhu An, ed. *Internal Fixation in Osteoporotic Bone*. New York, NY: Thieme; 2002:108–115.
77. Higgans TF, Klatt J, Bachus KN. Biomechanical analysis of bicondylar tibial plateau fixation: How does lateral locking plate fixation compare to dual plate fixation? *J Orthop Trauma*. 2007;21:301–306.
78. Hou S-H, Wang J-L, Lin J. Mechanical strength, fatigue life, and failure analysis of two prototypes and five conventional tibial locking screws. *J Orthop Res*. 2002;16:701–708.
79. Hufner T, Geerling J, Oldag G, et al. Accuracy study of computer assisted drilling: The effect of bone density, drill bit characteristics, and use of a mechanical guide. *J Orthop Trauma*. 2005;19:317–322.
80. Hughes AN, Jordan BA. The mechanical properties of surgical bone screws and some aspects of insertion practice. *Injury*. 1972;4:25–38.
81. Huiskes R, Chao EYS. Guidelines for external fixation frame rigidity and stresses. *J Orthop Res*. 1986;4:68–75.
82. Huiskes R, Chao EYS, Crippen TE. Parametric analyses of pin-bone stresses in external fracture fixation. *J Orthop Res*. 1985;3:341–349.
83. Hungerford DS, Barry M. Biomechanics of the patellofemoral joint. *Clin Orthop Rel Res*. 1979;144:9–15.
84. Isomi T, Panjabi MM, Wang J-L, et al. Stabilizing potential of anterior cervical plates in multilevel corpectomies. *Spine*. 1999;24:2219–2223.
85. Johnson KD, Tencer AF, Sherman MC. Biomechanical factors affecting fracture stability and femoral bursting in closed intramedullary nailing of femoral shaft fractures, with illustrative case presentations. *J Orthop Trauma*. 1987;1:1–11.
86. Kaab MJ, Frenk A, Schmeling A, et al. Locked internal fixator, sensitivity of screwplate stability to the correct insertion angle of the screw. *J Orthop Trauma*. 2004;18:483–487.
87. Kandziora F, Pflugmacher R, Schafer J, et al. Biomechanical comparison of cervical spine interbody fusion cages. *Spine*. 2001;26:1850–1857.
88. Karnezis IA, Miles AW, Cunningham JL, et al. Biological internal fixation of long bone fractures: A biomechanical study of a noncontact plate system. *Injury*. 1998;29:689–695.
89. Karunakar MA, Egol KA, Peindl R, et al. Split depression tibial plateau fractures: A biomechanical study. *J Orthop Trauma*. 2002;16:172–177.
90. Kirkpatrick JS, Levy JA, Carillo J, et al. Reconstruction after multilevel corpectomy in the cervical spine. *Spine*. 1999;24:1186–1191.
91. Klauke K, Perren SM, Kowalski M. Internal fixation with a self-compressing plate and screw: Improvements of the plate hole and screw design. I. Mechanical investigation. *J Orthop Trauma*. 1991;5:280–288.
92. Korner J, Diederichs G, Arzdorf M, et al. A biomechanical evaluation of methods of distal humerus fracture fixation using locking compression plates versus conventional reconstruction plates. *J Orthop Trauma*. 2004;18:286–293.
93. Kotani Y, Cunningham BW, Parker LM, et al. Static and fatigue biomechanical properties of anterior thoracolumbar instrumentation systems. *Spine*. 1999;24:1406–1413.
94. Krag MH. Biomechanics of thoracolumbar spinal fixation. A review. *Spine*. 1991;16:S85–S98.
95. Krag MH, Beynann BD, Pope MH, et al. An internal fixator for posterior application to short segments of the thoracic, lumbar, or lumbosacral spine. Design and testing. *Clin Orthop Rel Res*. 1986;203:75–98.
96. Krupp RJ, Malkani AL, Goodin RA, et al. Optimal entry point for retrograde femoral nailing. *J Orthop Trauma*. 2003;17:100–105.
97. Kubiak EN, Bong M, Park SS, et al. Intramedullary fixation of unstable intertrochanteric hip fractures. *J Orthop Trauma*. 2004;18:12–17.
98. Kyle RF, Wright TM, Burstein AH. Biomechanical analysis of the sliding characteristics of compression hip screws. *J Bone Joint Surg Am*. 1980;62A:1308–1314.
99. Laurence M, Freeman MA, Swanson SA. Engineering considerations in the internal fixation of fractures of the tibial shaft. *J Bone Joint Surg Am*. 1969;51B:754–768.
100. Law M, Tencer AF, Anderson PA. Caudo-cephalad loading of pedicle screws: Mechanisms of loosening and methods of augmentation. *Spine*. 1993;18:2438–2443.
101. Leibold NH, Cunningham BW, Dmitriev A, et al. Biomechanical comparison of lumbosacral fixation techniques in a calf spine model. *Spine*. 2002;27:2312–2320.
102. Leggon RE, Lindsey RW, Panjabi MM. Strength reduction and the effects of treatment of long bones with diaphyseal defects involving 50% of the cortex. *J Orthop Res*. 1988;6:540–546.
103. Leicher I, Margulies JY, Weimreb A, et al. The relationship between bone density, mineral content, and mechanical strength in the femoral neck. *Clin Orthop Rel Res*. 1982;163:272–281.
104. Leighton RK, Waddell JP, Bray TJ, et al. Biomechanical testing of new and old fixation devices for vertical shear fracture of the pelvis. *J Orthop Trauma*. 1991;5:313–317.
105. Lever JP, Aksenov SA, Zdero R, et al. Biomechanical analysis of plate osteosynthesis systems for proximal humerus fractures. *J Orthop Trauma*. 2008;22:23–29.
106. Liebschner MAK, Rosenberg WS, Keaveny TM. Effects of bone cement volume and distribution on vertebral stiffness after vertebroplasty. *Spine*. 2001;26:1547–1554.
107. Lim TH, Breback GT, Renner SM, et al. Biomechanical evaluation of an injectable calcium phosphate cement for vertebroplasty. *Spine*. 2002;27:1297–1302.
108. Lotz JC, Gerhart TN, Hayes WC. Mechanical properties of trabecular bone from the proximal femur by single-energy quantitative computed tomography. *J Comput Assist Tomogr*. 1990;14:107–114.
109. Mann KA, Bartel DL. A structural analysis of the fixation of pedicle screws to vertebrae. Paper presented at: 36th Annual Meeting of the Orthopedic Research Society; February 5–8, New Orleans, LA.
110. Marti A, Fankhauser C, Frenk A, et al. Biomechanical evaluation of the less invasive stabilization system for the internal fixation of distal femur fractures. *J Orthop Res*. 2001;15:482–487.
111. McBroom, RJ, Cheal EJ, Hayes WC. Strength reductions from metastatic cortical defects in long bones. *J Orthop Res*. 1988;6:369–378.
112. McElhanev JH. Dynamic response of bone and muscle tissue. *J Appl Physiol*. 1966;21:1231–1236.
113. McElhanev JH, Alem NM, Roberts VL. A porous block model for cancellous bone. *Am Soc Mech Eng*. 1970;70-WA/BHF-2-1–9.
114. McKoy BE, Conner GS, An YH. An interlocking screw for fixation in osteoporotic bone. In: An YH, ed. *Internal Fixation in Osteoporotic Bone*. New York, NY: Thieme; 2002: 237–241.
115. McLoughlin SW, Wheeler DL, Rider J, et al. Biomechanical evaluation of the dynamic hip screw with two and four-hole side plates. *J Orthop Trauma*. 2000;14:318–323.
116. Mehta M, Strube P, Peters A, et al. Duda Influences of age and mechanical stability on volume, microstructure, and mineralization of the fracture callus during bone healing: Is osteoclast activity the key to age-related impaired healing? *Bone*. 2010;47(2): 219–228.
117. Merk BR, Stern SH, Cordes S, et al. A fatigue life analysis of small fragment screws. *J Orthop Trauma*. 2001;15:494–499.
118. Meyer RW, Plaxton NA, Postak PD, et al. Mechanical comparison of a distal femoral side plate and a retrograde intramedullary nail. *J Orthop Trauma*. 2000;14:398–404.
119. Mihara H, Cheng BC, David SM, et al. Biomechanical comparison of posterior cervical fixation. *Spine*. 2001;26:1662–1667.
120. Mirza SK, Moquin RR, Anderson PA, et al. Stabilizing properties of the halo apparatus. *Spine*. 1997;22:727–733.
121. Misenhimer GR, Peek RD, Wiltze LL, et al. Anatomic analysis of pedicle canal and cancellous diameter related to screw size. *Spine*. 1989;14:367–372.
122. Molloy S, Jasper LE, Elliott DS, et al. Biomechanical evaluation of intramedullary nail versus tension band fixation for transverse olecranon fractures. *J Orthop Trauma*. 2004;18:170–174.
123. Moroni A, Aspenberg P, Toksvig-Larsen S, et al. Enhanced fixation with hydroxapatite coated pins. *Clin Orthop Rel Res*. 1998;346:171–177.
124. Muller ME, Allgower M, Schneider R, et al. *Manual of Internal Fixation*. Berlin: Springer-Verlag; 1979:85–96.
125. Nunamaker DM, Perren SM. A radiological and histological analysis of fracture healing using prebending of compression plates. *Clin Orthop Rel Res*. 1979;138:167–174.
126. Ostrum RF, Marcantonio A, Marburger R. A critical analysis of the eccentric starting point for trochanteric intramedullary femoral nailing. *J Orthop Trauma*. 2005;19:681–686.
127. Paul JP. Approaches to design, force actions transmitted by joints in the human body. *Proc Roy Soc London*. 1976;192:163–172.
128. Perren SM. Physical and biological aspects of fracture healing with special reference to internal fixation. *Clin Orthop Rel Res*. 1975;138:175–194.
129. Perren SM, Cordey J, Baumgart F, et al. Technical and biomechanical aspects of screws used for bone surgery. *Int J Orthop Trauma*. 1992;2:31–48.
130. Pierce MC, Valdevit A, Anderson L, et al. Biomechanical evaluation of dual energy A-ray absorptiometry for predicting fracture loads of the infant femur for injury investigation: An in vitro porcine model. *J Orthop Trauma*. 2000;14:571–576.
131. Rapoff AJ, Conrad BP, Johnson WM, et al. Load sharing in Premier and Zephir anterior cervical plates. *Spine*. 2003;28:2648–2651.
132. Ricci WM, Tornetta P III, Petteys T, et al. A Comparison of Screw Insertion Torque and Pullout Strength. *J Orthop Trauma*. 2010;24:374–378.
133. Ratcliff JR, Werner FW, Green JK, et al. Medial buttress versus lateral locked plating in a cadaver medial tibial plateau fracture model. *J Orthop Trauma*. 2007;21:444–448.
134. Richter M, Thermann H, Wippermann B, et al. Foot fractures in restrained front seat car occupants: A long-term study over 23 years. *J Orthop Trauma*. 2001;15:287–293.
135. Roberts CS, Dodds JC, Perry K, et al. Hybrid external fixation of the proximal tibia: Strategies to improve frame stability. *J Orthop Trauma*. 2003;17:415–420.
136. Rubin R, Trent P, Arnold W, et al. Knowles pinning of experimental femoral neck fractures: A biomechanical study. *J Trauma*. 1981;21:1036–1039.

137. Russell TA, Dingman CA, Wisniewski P. Mechanical and clinical rationale for femoral neck fracture fixation with a cephalomedullary interlocking nail. Paper presented at: 37th Annual Meeting of the Orthopedic Research Society; February 17–20, Washington, DC.
138. Russell TA, Leighton RK, Alpha-BSM Tibial Plateau Fracture Study Group. Comparison of autogenous bone graft and endothermic calcium phosphate cement for defect augmentation in tibial plateau fractures. A multicenter, prospective, randomized study. *J Bone Joint Surg Am.* 2008;90:2057–2061.
139. Russell TA, Taylor JC, LaVelle DG, et al. Mechanical characterization of femoral interlocking intramedullary nailing systems. *J Orthop Trauma.* 1991;5:332–340.
140. Sander TW, Trehan RW, Baswell I, et al. Development of a new orthopedic wire tester. *J Biomed Mat Res.* 1983;17:587–596.
141. Sanders R, Haidukewych GJ, Milne T, et al. Minimal versus maximal plate fixation techniques of the ulna: The biomechanical effect of number of screws and plate length. *J Orthop Res.* 2002;16:166–171.
142. Schatzker J, Sanderson R, Murnaghan JP. The holding power of orthopedic screws in vivo. *Clin Orthop Rel Res.* 1975;108:115–126.
143. Schawewcker F. *The Practise of Osteosynthesis. A Manual of Accident Surgery.* Chicago, IL: Yearbook Medical Publishers; 1974.
144. Schildhauer TA, LeDoux WR, Chapman JR, et al. Triangular osteosynthesis and iliosacral screw fixation for unstable sacral fractures: A cadaveric and biomechanical evaluation under cyclic loads. *J Orthop Trauma.* 2003;17:22–31.
145. Schuster I, Korner J, Arsdorf M, et al. Mechanical comparison in cadaver specimens of three different 90-degree double-plate osteosyntheses for simulated C2-type distal humerus fractures with varying bone densities. *J Orthop Trauma.* 2008;22:113–120.
146. Siffri PC, Peindl RD, Coley ER, et al. Biomechanical analysis of blade plate versus locking plate fixation for a proximal humerus fracture: Comparison using cadaveric and synthetic humeri. *J Orthop Trauma.* 2006;20:547–554.
147. Simonian PT, Rott ML, Harrington RM, et al. The unstable iliac fracture: A biomechanical evaluation of internal fixation. *Injury.* 1997;28:469–475.
148. Simonian PT, Schwappach JR, Rott MLC Jr, et al. Evaluation of new plate designs for symphysis pubis internal fixation. *J Trauma.* 1996;41:498–502.
149. Simonian PT, Thomson GT, Emley W, et al. Angled screw placement in the lateral condyle buttress plate for supracondylar femur fractures. Paper presented at: 43rd Annual Meeting of the Orthopedic Research Society; March 16–19, New Orleans, LA.
150. Singh K, Vaccaro AR, Kim J, et al. Biomechanical comparison of cervical spine reconstructive techniques after a multilevel corpectomy of the cervical spine. *Spine.* 2003;28:2352–2358.
151. Snow M, Thompson G, Turner PG. A mechanical comparison of the locking compression plate (LCP) and the low contact dynamic compression plate (DCP) in an osteoporotic bone model. *J Orthop Trauma.* 2008;22:121–125.
152. Spangler L, Cummings P, Tencer AF, et al. Biomechanical factors and failure of transcervical hip fracture repair. *Injury.* 2001;32:223–228.
153. Spears BR, Ostrum RF, Litsky AS. A mechanical study of gap motion in cadaver femurs using short and long supracondylar nails. *J Orthop Trauma.* 2004;18:354–360.
154. Stanekewich CJ, Swiontkowski MF, Tencer AF, et al. Augmentation of femoral neck fracture fixation with an injectable calcium-phosphate bone mineral cement. *J Orthop Res.* 1996;14:786–793.
155. Stanekewich CJ, Chapman J, Muthusamy R, et al. Relationship of mechanical factors to the strength of proximal femur fractures fixed with cancellous screws. *J Ortho Trauma.* 1996;10:248–257.
156. Streubel PN, Moustoukas MJ, Obrensky WT. Mechanical failure after locking plate fixation of unstable intertrochanteric femur fractures. *J Orthop Trauma.* 2013;27:22–28.
157. Stone JL, Beaupre GS, Hayes WC. Multiaxial strength characteristics of trabecular bone. *J Biomech.* 1983;16:743–752.
158. Swiontkowski MF, Harrington RM, Keller TS, et al. Torsion and bending analysis of internal fixation techniques for femoral neck fractures: The role of implant design and bone density. *J Orthop Res.* 1987;5:433–444.
159. Taitzman J, Saha S. Tensile properties of reinforced bone cement. *J Bone Joint Surg Am.* 1976;59A:419–425.
160. Tencer AF, Asnis SE, Harrington RM, et al. Biomechanics of cannulated and noncannulated screws. In: Asnis SE, Kyle RF, eds. *Cannulated Screw Fixation, Principles, and Operative Techniques.* New York, NY: Springer-Verlag; 1996.
161. Tencer AF, Claudi B, Pearce S, et al. Development of a variable stiffness fixation system for stabilization of segmental defects of the tibia. *J Orthop Res.* 1984;1:395–404.
162. Tencer AF, Hampton D, Eddy S. Biomechanical properties of threaded inserts for lumbar interbody spinal fusion. *Spine.* 1995;20:2408–2414.
163. Tencer AF, Kaufman R, Ryan K, et al. Estimating the loads in femurs of occupants in actual motor vehicle crashes using frontal crash test data. *Accident Analysis and Prevention.* 2002;34(1):1–11.
164. Van Audekercke R, Martens M, Mulier JC, et al. Experimental study on internal fixation of femoral neck fractures. *Clin Orthop Rel Res.* 1979;141:203–212.
165. Watford KE, Kregor PJ, Hartssock LA. LISS plate fixation of periprosthetic supracondylar femur fractures. In: An YH, ed. *Internal Fixation in Osteoporotic Bone.* New York, NY: Thieme; 2002:271–278.
166. Weaver JK, Chalmers J. Cancellous bone: Its strength and changes with aging and an evaluation of some methods for measuring its mineral content 1. Age changes in cancellous bone. *J Bone Joint Surg Am.* 1966;48A:289–299.
167. White AA III, Panjabi MM, Southwick WO. Effects of compression and cyclical loading on fracture healing—a quantitative biomechanical study. *J Biomech.* 1977A;10:233–239.
168. White AA III, Panjabi MM, Southwick WO. The four biomechanical stages of fracture repair. *J Bone Joint Surg Am.* 1977B;59A:188–192.
169. Wikenheiser MA, Lewallen DG, Markel MD. In vitro mechanical, thermal, and microstructural performance of five external fixation pins. Paper presented at: 38th Annual Meeting of the Orthopedic Research Society; February 17–20, Washington, DC.
170. Wittenberg RH, Shea M, Swartz DE, et al. Importance of bone mineral density in instrumented spinal fusions. *Spine* 1991;16:648–652.
171. Woodard PI, Self J, Calhoun JH, et al. The effect of implant axial and torsional stiffness on fracture healing. *J Orthop Trauma.* 1987;1:331–340.
172. Wright TM, Hayes WC. Tensile testing of bone over a wide range of strain rates: Effects of strain rate, microstructure, and density. *Med Biol Eng.* 1976;14:671–680.
173. Wu S-S, Edwards WT, Zou D, et al. Transpedicular vertebral screws in human vertebrae: Effect on screw-vertebra interface stiffness. Paper presented at: 38th Annual Meeting of the Orthopedic Research Society; February 17–20, Washington, DC.
174. Yerby S, Scott CC, Evans NJ, et al. Effect of cutting flute design on cortical bone screw insertion torque and pullout strength. *J Orthop Trauma.* 2001;15:216–221.
175. Yinger K, Scalise J, Olson SA, et al. Biomechanical comparison of posterior pelvic ring fixation. *J Orthop Trauma.* 2003;17:481–487.
176. Young JWR, Burgess AR, Brumback RJ. Lateral compression fractures of the pelvis; the importance of plain radiographs in the diagnosis and surgical management. *Skeletal Radiol.* 1986;15:103–109.
177. Zand MS, Goldstein SA, Matthews LS. Fatigue failure of cortical bone screws. *J Biomech.* 1983;16:305–311.
178. Zuber K, Schneider E, Eulenberger J, et al. Form und Dimension der Markhöhle menschlicher Femora in Hinblick auf die Passung von Marknagelimplantaten. *Unfallchirurg.* 1988;91:314–319.